

High Performance Composite Steel Deck-Slab with Dramix Steel Fiber Design Example

Patrick A. Bodwell

High Performance Composite Steel Deck-Slab with Dramix Steel Fiber Design Example

Patrick A. Bodwell

Verco Decking, Inc.

SEAOC Convention September 2021

Table of Contents

1.0	Steel Fiber Reinforced Steel Deck-Slabs	1
2.0	Dramix Steel Fiber Reinforced Steel Deck-Slab Fire Ratings	1
3.0	Dramix Steel Fiber Reinforced Steel Deck-Slab Serviceability	2
4.0	High Performance Deck-Slab Diaphragm Shear Strength	4
4.1.	Diagonal Tension Strength of Steel Deck-Slab	6
4.2.	Shear Transfer Connections Between Steel Deck-Slab and Chords or Collectors	12
4.3.	Nominal Connections Between Steel Deck-Slab and Support Framing	17
5.0	Vertical Uniform Loads and Concentrated Loads	20
5.1.	Vertical Uniform Loads	21
5.2.	Vertical Concentrated Loads	22
5.2.1.	Load Distribution for Strong Axis Bending	23
5.2.2.	Load Distribution for Weak Axis Bending	24
5.2.3.	Weak Axis Bending Moment	24
5.2.4.	Load Distribution for Punching Shear	25
5.3.	Composite Steel Deck-Slab Strength	25
5.3.1.	Composite Steel Deck-Slab Strong Axis Bending Strength and Vertical Shear	26
5.3.2.	Steel fiber Reinforced Concrete Weak Axis Bending Strength	26
5.3.3.	Steel Deck-Slab Punching Shear Strength.	28

1.0 Steel Fiber Reinforced Steel Deck-Slabs

Don't waste time installing time consuming welded wire fabric or rebar mats, just install steel deck and pour Dramix® steel fiber. Use Verco FormLok® composite steel deck with Bekaert Dramix steel fiber to replace the welded wire fabric or reinforcing bar mats in the composite steel deck-slab. This economical solution saves time and has established fire, serviceability, and structural performance. All of this can be delivered with ease, using Verco web-based design tools following methods recognized in IAPMO Product Evaluation Report ER-2018 and ER-0423.

- ✓ **Improve schedule**, install steel deck and pour Dramix steel fiber reinforced concrete without the delay to install welded wire fabric.
- ✓ **Fire rated**, Dramix is approved by UL for virtually all steel deck-slab floor assemblies.
- ✓ **Mitigate cracking**, Dramix meets the IBC and ANSI/SDI requirements for temperature and shrinkage reinforcement.
- ✓ **High shear strength**, Verco FormLok composite steel deck-slabs with Dramix steel fiber deliver superior diaphragm shear based on full-scale reverse cyclic diaphragm testing, ideal for high seismic applications.
- ✓ **Easy to design**, use web-based structural design tools to specify Verco FormLok composite steel deck-slabs with Dramix steel fiber reinforcement.

Gain all of this value by specifying Verco FormLok composite steel deck with Bekaert Dramix steel fiber reinforced concrete.

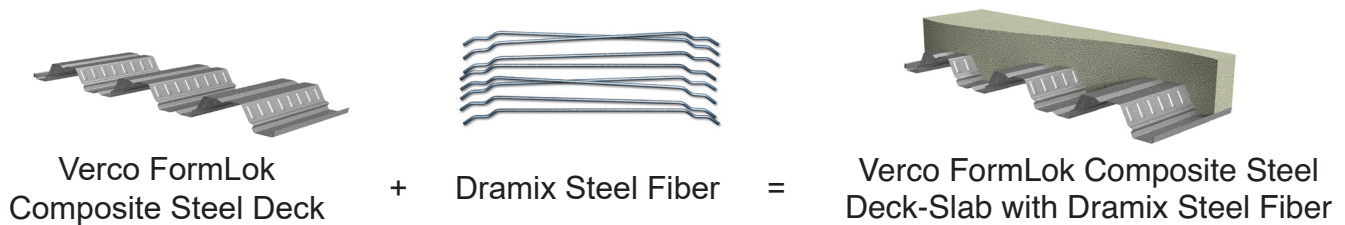

Figure 1.1 Composite Deck-Slab with Steel Fiber

2.0 Dramix Steel Fiber Reinforced Steel Deck-Slab Fire Ratings

Many structures require the floor and roof systems to have a minimum fire rating, typically either 1 or 2 hour rated. The fire rating is determined using ASTM E119 or UL 263 fire tests following IBC requirements. Most assemblies that include steel deck have been tested and are listed by Underwriters Laboratory (UL). These UL assemblies identify both the hourly fire rating and the specific materials that the assembly is comprised of. Assemblies with steel deck commonly use steel beam or open web steel joist framing, steel deck-slab, spray applied fire resistant materials, supplemental reinforcement in the concrete slab, and other assembly specific elements. Steel deck-slabs in UL listed assemblies commonly include 6 x 6 – W1.4 x W1.4 welded wire fabric in the concrete slab.

Bekaert Dramix steel fiber is UL approved as an alternate to welded wire fabric in Design Numbers D216, G229, G561, and all Floor-Ceiling D700, D800 and D900 Series Designs, with a maximum dosage of 66 lb/cy of steel fiber in the concrete. This is in accordance with UL CBXQ.R19307 Steel Fiber Reinforcement and Concrete Additives for Dramix Steel Fibers. This broad-based approval allows the Dramix steel fibers to be used in virtually all UL fire rated floor-ceiling assemblies.

3.0 Dramix Steel Fiber Reinforced Steel Deck-Slab Serviceability

The Dramix 4D series is designed with optimal serviceability in mind to mitigate temperature and shrinkage cracking. Dramix steel fiber is evenly distributed in the concrete to mitigate cracking as shown in Figure 3.1. Tensile strength and anchorage are engineered specifically to affect cracks between 0.004 in. and 0.01 in. Typical 4D steel fiber applications include steel deck-slab floors or roofs, and slabs on grade.

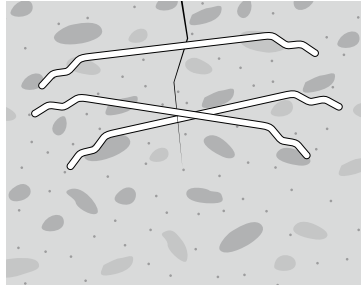

Figure 3.1 Dramix Steel Fiber Crack Mitigation

Dramix steel fiber reinforcement is an alternate to traditional welded wire fabric or reinforcing bars for temperature and shrinkage control. This is addressed directly in the ANSI/SDI C-2017 Standard for the Design of Composite Steel Floor Deck-Slabs which is specified in 2018 IBC Section 2210.1.1.3. SDI C-2017 Section 2.4B.15.a.2 prescribes that the steel fiber dosage shall be in accordance with manufacturer's recommendations, but not less than 25 lbs per cubic yard. Verco and Bekaert conducted research to develop the minimum dosage for Dramix steel fibers used for Verco steel deck-slabs based on equivalent tension strength of the Dramix steel fiber compared to the minimum area of the welded wire or reinforcing bars specified in C-2017. C-2017 Section 2.4B.15.a.1 Reinforcement for Temperature and Shrinkage for welded wire reinforcement or reinforcing bars specifies 0.00075 times the area of the concrete above the steel deck but not less than the area of 6 x 6 -W1.4 x W1.4. The dosage for Dramix steel fiber is based on equivalent tension strength to that of the minimum wire or reinforcement bars based on the approved minimum dosage in IAPMO ER-2018. This is based on the tensile strength of the Dramix steel fiber reinforced concrete with approved dosage for temperature and shrinkage below the recommended minimum of 25 lb/cy for generic steel fiber in SDI C-2017 Section 2.4B.15.a.2.

ANSI/SDI C-2017 Section 2.4B:

15. Reinforcement for Temperature and Shrinkage:

- a. Reinforcement for crack control purposes other than to resist stresses from quantifiable structural loadings shall be permitted to be provided by one of the following methods:
 1. Welded wire reinforcement or reinforcing bars with a minimum area of 0.00075 times the area of the concrete above the deck (per foot or meter of width), but not be less than the area provided by 6 x 6 – W1.4 x W1.4 (152 x 152 – MW9 x MW9) welded wire reinforcement.
 2. Concrete specified in accordance with ASTM C1116, Type I, containing steel fibers meeting the criteria of ASTM A820, Type I, Type II, or Type V, at a dosage rate determined by the fiber manufacturer for the application, but not less than 25 lb/cu yd (14.8 kg/cu meter).

To achieve equivalent performance the minimum dosage of Dramix steel fiber should meet the requirements set forth in IAPMO ER-2018 based on the approved underlying research. The solution requires solving for the dosage, D, using IAPMO equations BD-2 and BD-1 as follows in accordance with IAPMO ER-2018 Section 3.2.9.1 Minimum Temperature and Shrinkage reinforcement.

$$39.96 \cdot \lambda \cdot \sqrt{f'_c} \cdot D_c \cdot \frac{R_{T,150}^D}{100} \geq \max(540 \cdot D_c, 1680) \quad \text{ER-2018 Eq. BD-2}$$

Where:

$$R_{T,150}^D = C_1 \cdot \left(\frac{D}{\sqrt{f'_c}} \right)^2 + C_2 \cdot \left(\frac{D}{\sqrt{f'_c}} \right) \quad \text{ER-2018 Eq. BD-1}$$

Coefficients C_1 and C_2 are from Table 4.1

Coefficient	f_{r1}	f_{r4}	f_{150}	$R_{T,150}^D$
C_1	-81	-127	-127	-30
C_2	537	507	507	105

Table 3.1 Dramix Coefficients from ER-2018

D = Steel fiber dosage, pcy.

15 pcy ≤ D ≤ 66 pcy for Normal Weight Concrete

20 pcy ≤ D ≤ 66 pcy for Light Weight Concrete

D_c = Depth of concrete above steel deck flutes, in.

f'_c = Design strength of concrete, psi. ≥ 2500 psi

$R_{T,150}^D$ = Equivalent flexural stress ratio, % as defined by ASTM C1609.

λ = Concrete unit weight factor; 1.0 for NWC, 0.75 of LWC

Example 3.1

Determine the minimum dosage of Dramix 4D 65/60 BG steel fiber for temperature and shrinkage (T&S) for:

20 ga W3-36 FormLok deck with

6-1/4 inch, 110 pcf LWC, $f'_c = 3000$ psi

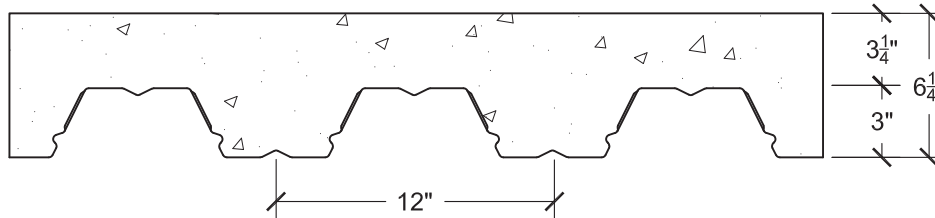

Figure 3.1 W3-36 FormLok Composite Steel Deck-Slab

For this example, the minimum permitted dosage of 20 lbs/cy for light weight concrete will be selected to check to see if the minimum dosage for temperature and shrinkage is satisfied.

$$R_{T,150}^D = -30 \cdot \left(\frac{20}{\sqrt{3000}} \right)^2 + 105 \cdot \left(\frac{20}{\sqrt{3000}} \right) = 34.3 \quad \text{ER-2018 Eq. BD-1}$$

$$39.96 \cdot 0.75 \cdot \sqrt{3000} \cdot 3.25 \cdot \frac{34.3}{100} = 1832 \geq 1755 = \max(540 \cdot 3.25, 1680) \quad \text{ER-2018 Eq. BD-2}$$

Therefore 20 lbs/cy of Dramix 4D 60/65 BG satisfies the minimum requirements for temperature and shrinkage.

4.0 High Performance Deck-Slab Diaphragm Shear Strength

High performance steel deck-slab diaphragms are ideally suited for high seismic and transfer diaphragm applications. The economy of Dramix steel fiber also allows high performance steel deck-slab diaphragms to be suitable for modest and low shear applications as well. Steel deck-slab diaphragm strength is governed by the diagonal tension strength of the steel deck-slab under shear loading and the strength of the shear transfer connections to diaphragm chords or collectors transferring forces to the vertical lateral force resisting system (VLFRS). This design method is based on the results of full-scale reverse cyclic steel deck-slab diaphragm testing performed at Virginia Tech. The resulting methods have been evaluated and recognized by IAPMO in Verco Product Evaluation Report ER-2018 and ER-0423.

Verco provides the design community with easy to use web-based design tools for most common applications of composite steel deck-slabs. This section goes through the design methods used in the Verco High Performance Steel Deck-Slab Diaphragm web-tool that can be accessed on the Verco website.

<https://vulcraft.com/Verco/HighPerformanceDeckSlabDiaphragmStrength>

The two limit states which govern the steel deck-slab diaphragm shear strength are illustrated in Figure 4.1. First, the diagonal shear strength is represented by the unit shear of the steel deck-slab. This is the strength of the field of the diaphragm based on the steel deck-slab. The second limit state is the shear transfer strength of the connections between the steel deck or steel deck-slab and the diaphragm chords or collectors shown as shear transfer arrows between the steel deck-slab and the support framing in Figure 4.1. The available strength of the steel deck-slab diaphragm is the limiting strength of the diagonal tension in the field, or the strength of the shear transfer at chord or collectors.

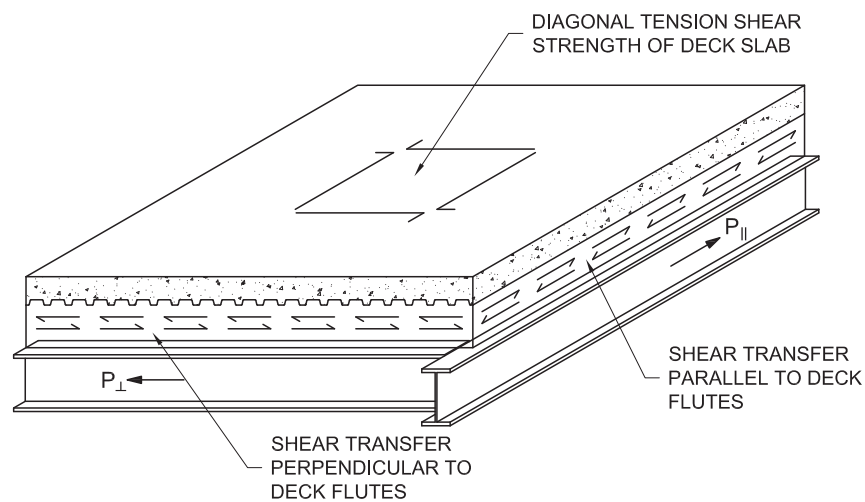

Figure 4.1 Steel Deck-Slab Diaphragm Strength

Noticeably absent from the diaphragm shear strength design, compared to historic methods, is that the connections between the deck-slab and support framing, that are not chords or collectors, do not contribute to the diaphragm shear strength. Figure 4.2 depicts the locations of chords and collectors on a typical deck-slab floor diaphragm. For this floor, the diaphragm chords are around the perimeter in line with the VLFRS moment frames, and collectors extend across the diaphragm at the re-entrant corners. The remainder of the gravity framing supports the deck-slab but is not a direct element of the VLFRS. This gravity framing is only required to have minimum nominal connections between the deck-slab and the support framing.

The design of the deck-slab diagonal tension strength, connection strength at chords or collectors, and the minimum nominal connections to gravity support framing is covered in the following sections.

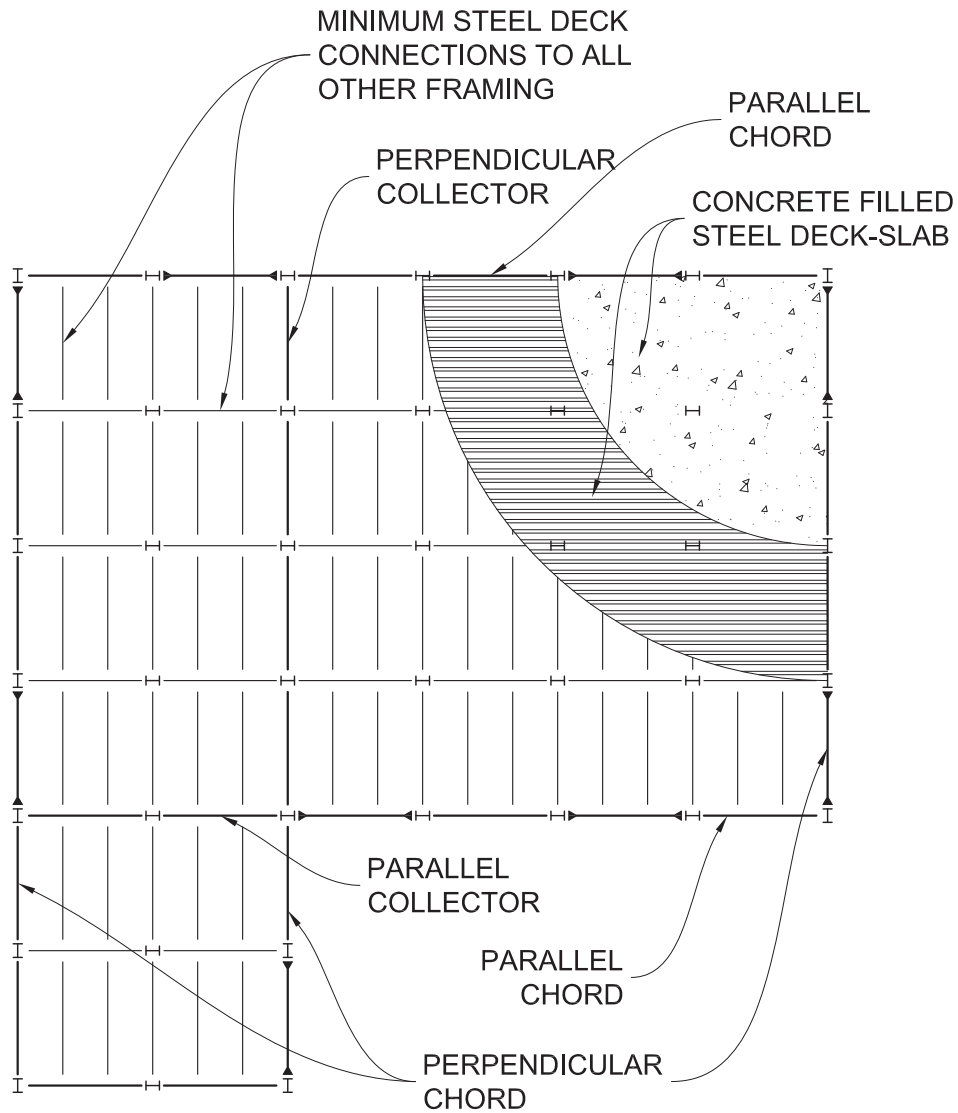

Figure 4.2 Deck-Slab Floor Diaphragm

4.1 Diagonal Tension Strength of Steel Deck-Slab

Diagonal tension in the steel deck-slab is analogous to reinforced concrete deep beam design in that a shear tension field develops in the concrete deck-slab diaphragm, similar to shear dominating flexural strength in design of a deep beam. Figure 4.3 shows typical diagonal tension cracks that developed in both directions, based on the direction of loading, during a reverse cyclic test.



Figure 4.3 Diagonal Tension Cracking of Steel Deck-Slab Diaphragm

The diaphragm shear strength limited by diagonal tension cracking of the steel deck-slab can be determined based on theory developed from full scale reverse cyclic testing performed at Virginia Tech. The resulting design equations from this research have been independently evaluated and recognized in IAPMO Product Evaluation Reports ER-2018 and ER-0423 for all load combinations, including seismic.

The diaphragm shear strength method is dependent on the steel deck with the plain concrete fill and when used, the additive effect of the Dramix steel fiber reinforcement in the concrete.

Design Shear Strength of Steel Deck-Slab

$$S_n = S_c + S_f \quad \text{ER-2018 Eq. C-1}$$

The available strength

$$S_a = \phi S_n$$

Where:

S_n = Nominal shear strength per unit length of diaphragm system with concrete fill, k/ft

S_c = Shear strength of steel deck and structural concrete calculated in accordance with Eq. C-2, k/ft

S_f = Bekaert Dramix steel fiber contribution to shear strength calculated in accordance with IAPMO ER-2018 Eq. C-3

ϕ = 0.80 resistance factor for LRFD

Plain Concrete Steel Deck-Slab Strength

$$S_c = k_c \cdot \lambda \cdot b \cdot \left[\left(D_c + \frac{D_d}{2} \right) + t \cdot \left(\frac{E}{E_c} \right) \cdot \left(\frac{d}{s} \right) \right] \cdot \sqrt{f'_c} \quad \text{ER-2018 Eq. C-2}$$

Where:

k_c = Factor for structural concrete strength = 3.2/1000

λ = Concrete unit weight factor; 1.0 for NWC, 0.75 of LWC.

b = Unit width of diaphragm with structural concrete fill = 12 in.

D_c = Depth of concrete cover above steel deck flutes, in.

D_d = Depth of steel deck, in.

D = Steel fiber dosage, pcy

t = Base steel thickness of panel, in.

E = Modulus of elasticity of steel

E_c = Modulus of elasticity of concrete, psi ACI 318-14
= $w_c^{1.5} \cdot 33 \sqrt{f'_c}$, psi, for $90 \text{ pcf} \leq w_c \leq 160 \text{ pcf}$ Eq. 19.2.2.1.a

w_c = unit weight of concrete, pcf

d = Panel corrugation pitch, in.

s = Developed flute width of single corrugation, in.

f'_c = Structural concrete compressive strength, psi ≥ 2500 psi

Dramix Steel Fiber Reinforcement Contribution

For $D \geq 35$ pcy:

$$S_f = 0.37 \cdot f_{150} \cdot \left(D_c + \frac{D_d}{2} \right) \quad \text{ER-2018 Eq. C-3}$$

For $D < 35$ pcy:

$$S_f = 0$$

Where:

f_{150} = Stress at L/150 (psi)

$$f_{150} = C_1 \cdot \left(\frac{D}{\sqrt{f'_c}} \right)^2 + C_2 \cdot \left(\frac{D}{\sqrt{f'_c}} \right) \quad \text{ER-2018 Eq. BD-1}$$

Where coefficients C1 and C2 are presented in Table 3.1. Composite deck-slab diaphragms are classified as rigid diaphragms with a shear stiffness typically over 1000 kip/ft.

The shear stiffness for a specific steel deck-slab combination can be predicted based on Equation C-4 in IAPMO ER-2018.

$$G' = 4.8 \cdot \left[\left(D_c + \frac{D_d}{2} \right) + t \cdot \left(\frac{E}{E_c} \right) \cdot \left(\frac{d}{s} \right) \right] \cdot \sqrt{f'_c} \quad \text{ER-2018 Eq. C-4}$$

Where:

G' = Shear stiffness of concrete deck-slab diaphragm, k/in

The following example provides a typical design for a common steel deck-slab suitable for a multi-story 2-hour fire rated floor system.

Example 4.1

20 ga W3-36 FormLok deck as shown in Figure 3.1 with

6-1/4 inch, 110 pcf LWC, $f'_c = 3000$ psi, and

35 pcy Dramix 4D 65/60 BG steel fiber

The properties for the W3-36 FormLok composite steel deck are from IAPMO ER-2018 as shown in Figure 4.4

Embossed Profiles
 PLW3-36 FormLok,
 W3-36 FormLok,
 W3-36-SS FormLok

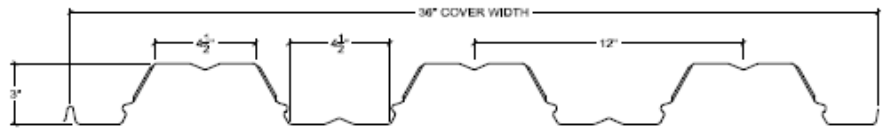

Gage	t in.	w _{dd} psf	A _g in ² /ft	I _{xg} in ⁴ /ft	S _{xh} in ³ /ft	S _{xt} in ³ /ft	y _b in.	y _t in.	r in.	h _w in.	θ deg.	K _{min} -
22	0.0299	1.9	0.497	0.761	0.515	0.490	1.478	1.552	1.237	3.113	63.2	0.000
21	0.0330	2.1	0.548	0.840	0.568	0.541	1.480	1.553	1.238	3.113	63.1	0.000
20	0.0359	2.3	0.596	0.914	0.617	0.588	1.481	1.555	1.238	3.112	63.1	0.000
19	0.0420	2.7	0.697	1.068	0.719	0.685	1.485	1.558	1.238	3.110	63.0	0.000
18	0.0478	2.9	0.793	1.214	0.816	0.778	1.488	1.560	1.237	3.108	63.0	0.000
16	0.0598	3.5	0.991	1.517	1.015	0.969	1.494	1.566	1.237	3.105	62.9	0.000

GRADE 50: F _y = 50 ksi, F _u = 65 ksi												
Gage	I _{e+} in ⁴ /ft	I _{e-} in ⁴ /ft	I _{d+} in ⁴ /ft	I _{d-} in ⁴ /ft	S _{e+} in ³ /ft	S _{e-} in ³ /ft	M _{n+} k-ft/ft	M _{n-} k-ft/ft	M _{nt+} k-ft/ft	M _{nt-} k-ft/ft	V _n k/ft	T _n k/ft
22	0.723	0.715	0.736	0.730	0.393	0.410	1.638	1.708	2.146	2.042	2.183	24.85
21	0.816	0.806	0.824	0.817	0.453	0.470	1.888	1.958	2.367	2.254	2.932	27.40
20	0.904	0.892	0.907	0.899	0.510	0.528	2.125	2.200	2.571	2.450	3.776	29.80
19	1.067	1.058	1.067	1.061	0.636	0.652	2.650	2.717	2.996	2.854	5.295	34.85
18	1.213	1.210	1.213	1.211	0.752	0.768	3.133	3.200	3.400	3.242	6.858	39.65
16	1.515	1.516	1.516	1.516	0.968	0.966	4.033	4.025	4.229	4.038	9.918	49.55

Gage	A _{gtf} in ²	A _{stf} in ²	I _{sptf} in ⁴	A _{gbf} in ²	A _{sbf} in ²	I _{spbf} in ⁴
22	0.132	0.036	0.001	0.132	0.036	0.001
21	0.146	0.040	0.001	0.146	0.040	0.001
20	0.159	0.043	0.001	0.159	0.043	0.001
19	0.186	0.050	0.002	0.186	0.050	0.002
18	0.211	0.057	0.002	0.211	0.057	0.002
16	0.263	0.072	0.002	0.263	0.072	0.002

b _{otf} in.	b _{ptf} in.	c _{stf} in.	b _{obf} in.	b _{pbf} in.	c _{sbf} in.
4.198	1.599	2.099	4.198	1.599	2.099

R in.	w _{tf} in.	w _{bf} in.
0.188	4.198	4.198

Figure 4.4 W3-36 FormLok Properties

Where:

$$k_c = 0.0032$$

$$\lambda = 0.75$$

$$b = 12 \text{ in/ft}$$

$$D_c = 3.25 \text{ in.}$$

$$D_d = 3.0 \text{ in.}$$

$$D = 35 \text{ pcy}$$

$$t = 0.0359 \text{ in.}$$

$$e = 2.25 \text{ in}$$

$$E = 29500 \text{ ksi}$$

$$f = 4.5 \text{ in.}$$

$$d = 12 \text{ in.}$$

$$f'_c = 3000 \text{ psi}$$

$$w_c = 110 \text{ pcf}$$

$$E_c = 110^{1.5} \cdot 33\sqrt{3000} = 2085 \text{ ksi}$$

$$s = 2e + f + 2\sqrt{\left(\frac{d}{2} - \frac{f}{2} - e\right)^2 + (D_d)^2} = 15.708 \text{ in.}$$

$$S_c = 0.0032 \cdot 0.75 \cdot 12 \cdot \left[\left(3.25 + \frac{3.0}{2} \right) + 0.0359 \cdot \left(\frac{29500}{2085} \right) \cdot \left(\frac{12}{15.708} \right) \right] \cdot \sqrt{3000} = 8.105 \text{ kip/ft}$$

ER-2018 Eq. C-2

$$f_{150} = -127 \cdot \left(\frac{35}{\sqrt{3000}} \right)^2 + 507 \cdot \left(\frac{35}{\sqrt{3000}} \right) = 272 \text{ psi}$$

ER-2018 Eq. BD-1

Where the coefficients C_1 and C_2 are from Table 3.1

ER-2018 Eq. C-3

Diaphragm Design Strength:

$$S_n = 8.105 + 5.739 = 13.844 \text{ kip/ft}$$

ER-2018 Eq. C-1

$$\phi = 0.80$$

$$\phi S_n = 0.80(13.844) = 11.075 \text{ kip/ft} = 11705 \text{ lbs/ft}$$

The corresponding diaphragm shear stiffness for this rigid steel deck-slab may be determined with the following for the structure.

$$G' = 4.8 \cdot \left[\left(3.25 + \frac{3.0}{2} \right) + 0.0359 \cdot \left(\frac{29500}{2085} \right) \cdot \left(\frac{12}{15.708} \right) \right] \cdot \sqrt{3000} = 1351 \text{ kip/in.}$$

ER-2018 Eq. C-4

The design shear strength of 11705 plf is the strength of the field of the diaphragm, which must exceed the factored shear required. The next step is to design the connections to transfer the required factored shear from the diaphragm to the chords and collectors.

4.2 Shear Transfer Connections Between Steel Deck-Slab and Chords or Collectors

The diaphragm shear force is transferred to the chord or collectors by the connections between the steel deck or steel deck-slab and chords or collectors. Welded headed shear stud anchors are a common connection to transfer high shear forces between the chord or collector and the steel deck-slab. These transfer very high shear forces because they connect both the steel deck and the concrete fill directly to the chord or collector. Arc spot welds, self-drilling screws, and power actuated fasteners (pins / nails) are also very good shear transfer connections for low to modest shear requirements. These rely on the strength of the steel deck to transfer the force between the chord or collector and the steel deck-slab assembly.

The connection design strength, ϕQ_n , must meet or exceed the required shear strength, V .

$$\phi Q_n \geq V$$

The resistance factor for the connection design for this deck-slab diaphragm shear strength method is in accordance with IAPMO Product Evaluation Report ER-2018.

- ϕ = Resistance factor for deck-slab diaphragm connections
- = 0.55 for welded steel headed stud anchors in accordance with ER-2018
- = Varies for welds in accordance with AISI S100-16
- = Varies for screws in accordance with AISI S100-16
- = Varies for proprietary fasteners (PAF, Shearflex® Screws, etc.) in accordance with ER-2018

Welded headed shear stud strength is determined in accordance with AISC 360-16 Section I8.2a with the resistance factor in accordance with IAPMO ER-2018. Shear strength for individual weld or screw connections are determined in accordance with AISI S100-16. Individual connection shear strength for Hilti or Pneutek power actuated fasteners, Simpson proprietary screws, and Shearflex fasteners are determined in accordance with the design equations in IAPMO ER-2018. Refer to IAPMO ER-2018 for more detail.

Stud strength Perpendicular to Rib of the Steel Deck.

$$Q_n = 0.5A_{sa}\sqrt{f'_c E_c} \leq R_g R_p A_{sa} F_u$$

AISC 360-16 Eq. I8-1

Where:

$$A_{sa} = \pi \left(\frac{d_s}{2} \right)^2$$

A_{sa} = cross-sectional area of steel headed stud anchor, in².

d_s = Diameter of the headed stud anchor, in.

E_c = modulus of elasticity of concrete, ksi

$$= w_c^{1.5} \cdot \sqrt{f'_c}, \text{ksi}$$

F_u = Specified minimum tensile strength of a steel headed stud anchor, ksi

The shear stud factors, R_g and R_p from AISC 360 are presented in Table 4.2.

Condition	R_g	R_p
No decking	1.0	0.75
Decking oriented parallel to the steel shape		
$w_r / h_r \geq 1.5$	1.0	0.75
$w_r / h_r < 1.5$	0.85 ^a	0.75
Decking oriented perpendicular to the steel shape		
Number of steel headed stud anchors occupying the same decking rib:		
1	1.0	0.6 ^b
2	0.85	0.6 ^b
3 or more	0.7	0.6 ^b
Where:		
h_r = Nominal rib height, in.		
w_r = Average width of concrete rib or haunch (as defined in Section I3.2c), in.		
Notes:		
a. For a single steel headed stud anchor		
b. This value may be increased to 0.75 when $e_{\text{mid-ht}} \geq 2$ in.		

Table 4.2 R_g and R_p Factors

The following examples are based on the 20 gage W3-36 FormLok deck with 6-1/4 in., 3000 psi LWC from the steel deck-slab shear strength example. Determination of the spacing of the shear transfer connections to meet the factored design shear from the steel deck-slab to the diaphragm chord or collector is illustrated for welded headed shear stud anchors in Example 4.2a or power actuated fasteners in Example 4.2b.

Example 4.2a

Determine the spacing for $\frac{3}{4}$ " welded headed steel stud anchors to transfer, $\bar{V} = 4500$ plf, factored diaphragm shear between the steel deck-slab and the diaphragm chord or collector.

Shear Stud, $d = \frac{3}{4}$ in. with an ultimate strength, $F_u = 65$ ksi.

For this example, two assumptions must be made to start the design. Based on experience, for this modest required shear we will assume that not more than one welded headed stud anchor will be required in any one rib of the steel deck. This is an important assumption because 2 or more studs per rib reduces the design strength of the individual stud compared to a single stud per rib. The second assumption will be that the studs will be in weak position with the stud less than 2 in. from the web at mid-height as shown in Figure 4.5. This is an appropriate assumption because most diaphragm shear loads for seismic or wind may be in either direction therefore the stud will be in weak position for one of the two possible loading directions.

Perpendicular Stud Spacing:

$$d_s = \frac{3}{4} \text{ in. diameter}$$

$$A_{sa} = \pi \left(\frac{0.75}{2} \right)^2 = 0.442 \text{ in}^2$$

$$E_c = 110^{1.5} \cdot \sqrt{3000} = 2085 \text{ ksi} \quad \text{AISC 360-16 §12.1b}$$

$$F_u = 65 \text{ ksi}$$

$$f'_c = 3 \text{ ksi}$$

$$R_g = 1.0 \text{ for 1 stud per rib} \quad \text{AISC 360-16 §18.2a}$$

$$R_p = 0.6 \quad \text{AISC 360-16 §18.2a}$$

$$Q_n = 0.5 \cdot 0.442 \sqrt{3 \cdot 2085} = 17.471 \geq 17.230 = 1.0 \cdot 0.6 \cdot 0.442 \cdot 65$$

Governing $Q_n = 17.230$ kips

$$\phi = 0.55$$

$$\phi Q_n = 0.55 (17.238) = 9.476 \text{ kips}$$

$$s = \frac{\phi Q_n}{Q_a} = \frac{9.481 \text{ kip}}{4.5 \text{ kip/ft}} = 2.1 \text{ ft} = 25 \text{ in.} \leq 36 \text{ in. maximum}$$

The pitch, or rib spacing, of W3-36 FormLok deck is 12 inches, therefore 1 stud every other rib at 24 inch o.c. is the pattern that will meet the minimum spacing of 25 in. o.c. This is less than the maximum permitted stud spacing of 36 in. o.c. in AISC 360-16 Section I8.2d(e), therefore acceptable.

Use 1 stud in every other rib for perpendicular conditions as shown in Figure 4.5.

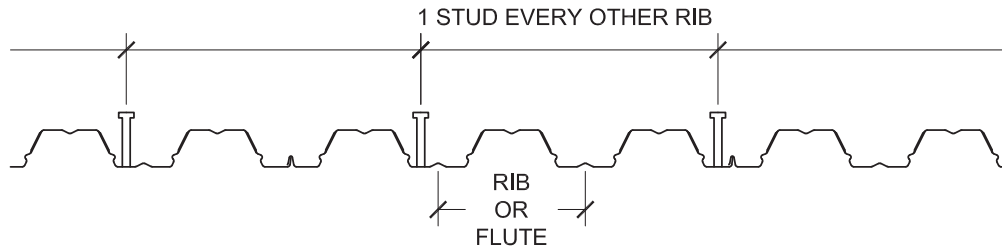

Figure 4.5 Shear Stud Attachment Pattern

Stud Spacing Parallel with Ribs:

$$d_s = \frac{3}{4} \text{ in. diameter, in.}$$

$$A_{sa} = \pi \left(\frac{0.75}{2} \right)^2 = 0.442 \text{ in}^2$$

$$E_c = 110^{1.5} \cdot \sqrt{3000} = 2085 \text{ ksi}$$

AISC 360-16 §12.1b

$$F_u = 65 \text{ ksi}$$

$$F'_c = 3 \text{ ksi}$$

$$R_g = 1.0$$

AISC 360-16 §18.2a

$$R_p = 0.75 \text{ for steel deck with } e_{\text{mid-ht}} \geq 2 \text{ in.}$$

AISC 360-16 §18.2a

$$Q_n = 0.5 \cdot 0.442 \sqrt{3 \cdot 2085} = 17.471 \text{ kip}$$

$$Q_n \leq 1.0 \cdot 0.75 \cdot 0.422 \cdot 65 = 21.537 \text{ kip}$$

Governing $Q_n = 17.471$ kips

$$\phi = 0.55$$

$$\phi Q_n = 0.55 (17.471) = 9.609 \text{ kips}$$

$$s = \frac{\phi Q_n}{\bar{V}} = \frac{9.481 \text{ kip}}{4.5 \text{ kip/ft}} = 2.11 \text{ ft} = 25.3 \text{ in.} \leq 36 \text{ in. o.c.}$$

The spacing for shears studs in the ribs parallel to supports is therefore limited by 25 in. o.c. This is less than the maximum permitted stud spacing of 36 in. o.c. in AISC 360-16 Section I8.2d(e), therefore acceptable.

Use 1 row of studs at 25 in o.c. in parallel conditions as shown in Figure 4.6.

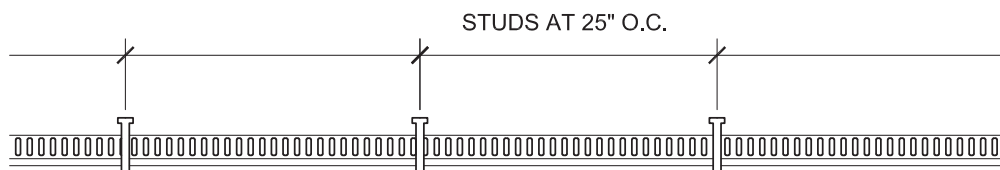

Figure 4.6 Shear Stud Attachment Pattern

Example 4.2b

Determine the spacing for Hilti X-ENP19 power actuated fasteners to transfer, $\bar{V} = 4500$ plf, factored diaphragm shear between a chord or collector and the deck slab.

The shear strength for the Hilti X-ENP19 power actuated fastener is in accordance with the strength provision in IAPMO Product Evaluation Report ER-2018.

$$P_{nf} = 56 \cdot t_1(1 - t_1)$$

ER-2018 Eq. H-1

Where:

$$t_1 = 0.0359 \text{ in}$$

$$\phi = 0.70 \text{ Resistance factor}$$

For 20 gage W3-36 FormLok deck

$$P_{nf} = 56 \cdot 0.0359(1 - 0.0359) = 1.938 \text{ kips}$$

ER-2018 Eq. H-1

$$\phi P_{nf} = 0.70 (1.938) = 1.357 \text{ kips}$$

$$s = \frac{\phi Q_{nf}}{\bar{Q}} = \frac{1.357 \text{ kip}}{4.5 \text{ kip/ft}} = 0.30 \text{ ft} = 3.62 \text{ in.}$$

The maximum attachment spacing is therefore 1 row of Hilti X-ENP19 PAF's at 3.62 in. o.c.

The perpendicular attachment pattern to the steel deck where the deck pitch (rib spacing) is 12 in.

$$\frac{12 \text{ in/rib}}{3.62 \text{ in}} = 3.31 \text{ per rib}$$

Therefore 3 per rib + 1 every other rib will be acceptable.

$$12 \text{ in} \left(\frac{3 \text{ PAF's}}{12 \text{ in}} + \frac{1 \text{ PAF}}{2 \cdot 12 \text{ in}} \right) = 3.5 \text{ per rib} \geq 3.31 \text{ per rib required}$$

The pitch (rib spacing) of W3-36 FormLok deck is 12 inches therefore 3 Hilti X-ENP19 PAF's per rib and 1 additional Hilti X-ENP19 PAF every other rib with an average of 3.5 PAF's per rib results in spacing of 3.43 in. is less than the maximum spacing of 3.62 in. maximum average spacing.

$$\text{Average PAF spacing} = \frac{12 \text{ in/rib}}{3.5/\text{rib}} = 3.43 \text{ in. o. c.} \leq 3.62 \text{ in. o. c.}$$

Use Hilti X-ENP19 connections at 3 per rib + 1 every other rib as shown in Figure 4.7

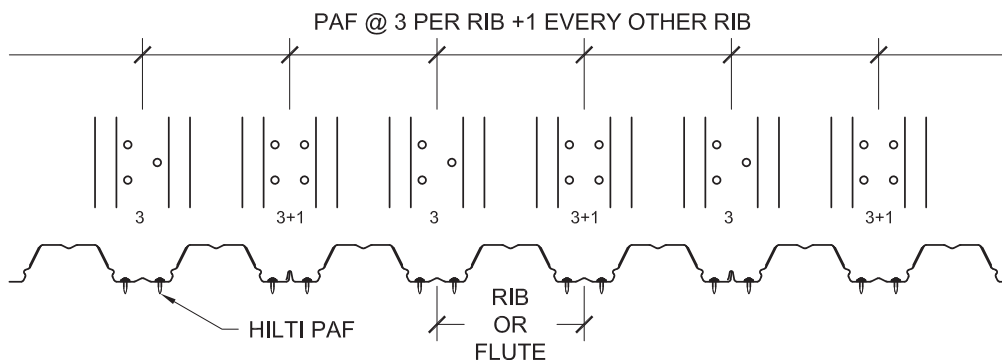

Figure 4.7 Hilti X-ENP19 Attachment Pattern

For a design in which both perpendicular and parallel connections to chords and collectors has equal strength, the parallel spacing should not exceed the average perpendicular spacing. In this balanced condition the design the parallel spacing is set to a maximum of 3.62 in o.c. as shown in Figure 4.8.

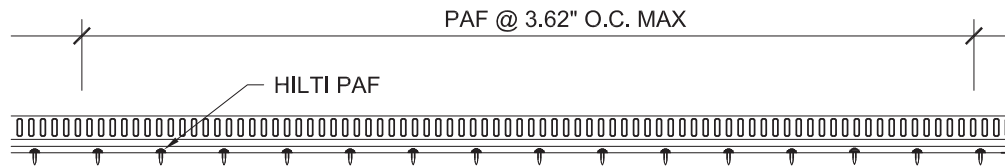

Figure 4.8 Parallel PAF Pattern

The shear transfer connection examples show both welded headed shear studs and Hilti power actuated fasteners are good solutions. The best solution will take the combined effort of the design professional and the construction team to determine which method is most economical for the project.

Strikingly absent from the design of the steel deck-slab diaphragm are the connections to support members that are not a chord or collector. The minimum required connections will be explored in the following section.

4.3 Nominal Connections Between Steel Deck-Slab and Support Framing

The steel deck standards prescribe a minimum attachment to all support members. This spacing is intended to provide a minimum level of positive attachment between the steel deck and the support framing when specific structural loads are not applied to those connections. It is important to note that these connections in the field of the diaphragm which do not transfer forces to chords or collectors, are not considered in the determination of the steel deck-slab diaphragm strength. This opens the door to using any suitable steel deck to support connection type, including welded headed shear stud anchors, arc spot welds, power actuated fasteners, self-drilling screws, and other suitable positive connections.

The minimum attachment for connection to support member that are perpendicular to the steel deck is specified in ANSI/SDI C-2017 Section 3.1.B which is specified in 2018 IBC Section 2210.1.1.3.

ANSI/SDI C-2017 Section 3.1.B

Deck Support Attachment: Steel deck shall be anchored to structural supports by arc spot welds, fillet welds, or mechanical fasteners. The average attachment spacing of deck at supports perpendicular to the span of the deck panel shall not exceed 16 inches (400 mm) on center, with the maximum attachment spacing not to exceed 18 inches (460 mm), unless more frequent fastener spacing is required for diaphragm design. The deck shall be adequately attached to the structure to prevent the deck from slipping off the supporting structure.

In accordance with SDI C-2017 Section 3.1B, the maximum connection spacing of the steel deck to support members.

$$s_{\text{avg}} \leq 16 \text{ in. o.c.}$$

$$s_{\text{max}} \leq 18 \text{ in. o.c.}$$

Minimum perpendicular connections for W3-36 FormLok deck with a pitch, or rib spacing, of 12

inches. Connections at every other rib would be at 24 in. o.c. exceeding both the maximum and average connection spacing, therefore the maximum spacing of connections is 1 in every rib, or 12 inches o.c.

Use perpendicular connection pattern of 1 per rib.

The minimum attachment for connection to perimeter support members that are parallel to the steel deck is specified in ANSI/SDI C-2017 Section 3.1.D which is specified in 2018 IBC Section 2210.1.1.3.

ANSI/SDI C-2017 Section 3.1.D

Deck Perimeter Attachment Along Edges Between Supports: Support at the perimeter of the floor shall be designed and specified by the designer. For deck with spans less than or equal to 5 feet (1.5 m), perimeter attachment shall not be required, unless required for diaphragm design. For deck with spans greater than 5 feet (1.5 m), perimeter edges of deck panels between span supports shall be fastened to supports at intervals not to exceed 36 inches (1 m) on center, unless more frequent fastener spacing is required for diaphragm design, using one of the following methods:

1. Screws with a minimum diameter of 0.190 inches (4.83 mm) (#10 diameter)
2. Arc spot welds with a minimum 5/8 inch (16 mm) minimum visible diameter, or minimum 1-1/2 inch (38 mm) long fillet weld.
3. Powder actuated or pneumatically driven fasteners.

For general design in which the support spacing is not known, the 36 in. o.c. limit is conservative for all conditions. In this case the maximum spacing for connections can be as great as 36 in. o.c.

Example 4.3

Determine the minimum connections for Example 3 with 20 ga W3-36 FormLok deck with 6-1/4 in., 3000 psi, 110 pcf LWC connected to chords and collectors with 3/4 in. welded headed shear stud anchors from Example 4.2.

Minimum Perpendicular Attachment to Chords or Collectors.

The welded headed shear stud anchor spacing is 1 in every other rib to transfer the 4500 plf factored diaphragm shear. The minimum required deck connection spacing following the provisions of SDI C-2017 for W3-36 FormLok deck is 1 per rib. This requires a connection in the intermediate ribs between the welded headed shear studs. Doubling the number of welded headed shear stud anchors to locate 1 in every rib would add significant additional construction cost, therefore a lower cost nominal infill connection is recommended. Power actuated fasteners (PAF's) are an excellent solution for these nominal infill connections between the shears studs that are transferring the shear for the diaphragm to the chord or collector. Figure 4.9 shows the infill connection in the intermediate ribs between the shear studs. Arc spot welds or self-drilling screws may also be suitable depending on the support member thickness.

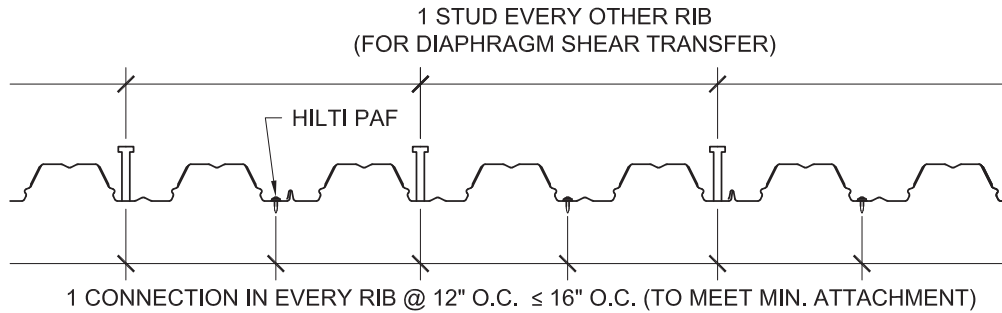

Figure 4.9 Minimum Connection to Perpendicular Chords and Collectors

Minimum Parallel Attachment Spacing to Chords or Collectors.

The welded headed shear stud anchor spacing is 25 in. o.c. parallel with the ribs to transfer the 4500 plf factored diaphragm shear. At chords and collectors, the minimum attachment must be satisfied. For the example with welded-headed shear stud anchors the minimum connection parallel with the ribs of 25 in. o.c. is less than the maximum average spacing set in SDI C-2017 of 36 in. o.c. In this case the minimum parallel connection pattern is met by the welded headed shear studs at 25 in. o.c. and no additional connections are required as shown in Figure 4.10.

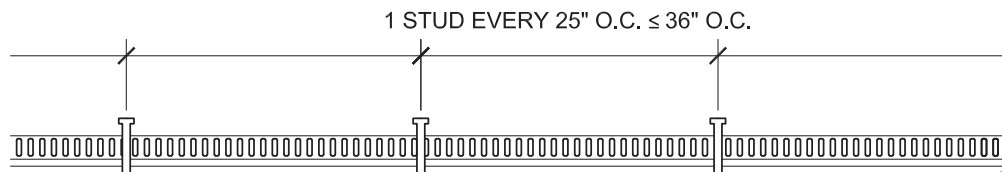

Figure 4.10 Minimum Connection to Parallel Chords and Collectors

Minimum Connections to support members that are not chords or collectors.

The remaining connections to the support members that are not chords or collectors are not assumed to transfer any shear force from the steel deck-slab to the support members. For these members, the minimum connection requirements of SDI C-2017 govern. The perpendicular pattern is therefore 1 per rib at 12 in. oc., which is less than the maximum of 16 in. o.c. For parallel conditions a minimum spacing of 36 in. o.c. is required except there are no connections required if the deck span is less than 5 ft. For general design a minimum of 36 in. o.c. will be selected for all conditions. Figure 4.11a and 4.11b show these typical connection patterns. These may be economical power actuated fasteners, more costly arc spot welds, or self-drilling screws for suitable substrate thicknesses.

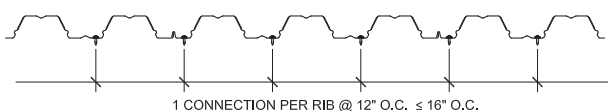

Figure 4.11a



Figure 4.11b

Minimum Connections to Composite Beams or Composite Open Web Steel Joists.

When steel deck-slabs are supported by composite beams or open web steel joists that require headed shear stud anchors for composite action, the process of determining the minimum steel deck connections still applies and additional connections may be required to meet those minimums. Figure 4.12 shows a common condition with shear studs at 24 in. o.c. and infill power actuated fasteners at 12 in. o.c. in W3-36 FormLok deck.

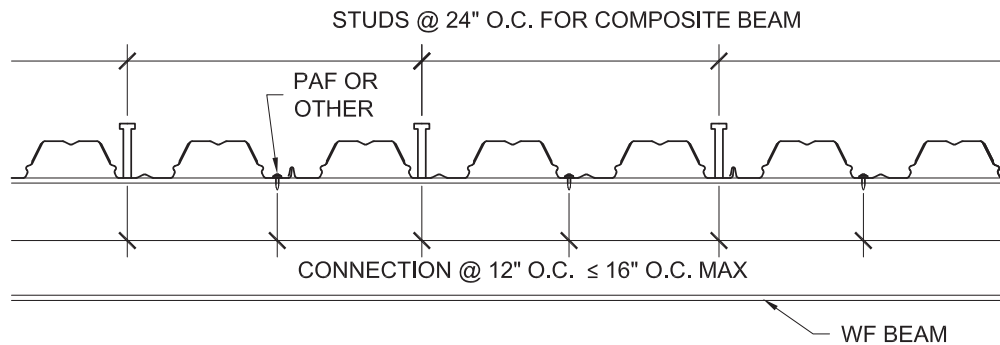

Figure 4.12 Minimum Connection to Perpendicular Chords and Collectors for Composite Beams with Studs at 24 in. o.c.

5.0 Vertical Uniform Loads and Concentrated Loads

There are several methods to design a composite steel deck-slab to support vertical uniform or concentrated loading following the provisions in ANSI/SDI C-2017 in accordance with 2018 IBC Section 2210.1.1.3. This includes the yield strength method, ultimate strength method, and shear-bond method. Each of these methods are acceptable based on appropriate detailing and testing of the deck-slab bond strength. Verco composite steel deck-slabs designed using the web-based Composite Deck-Slab Strength tool follow the yield strength method, supplemented with composite deck-slab flexural testing to develop a bond coefficient, K , between the steel deck and concrete tailored to the Verco profiles. The resulting bond coefficient from testing has been independently reviewed and reported in IAPMO Product Evaluation Report ER-2018. This method determines the bending strength and vertical shear strength of the Verco composite deck-slab as shown in Figure 5.1.

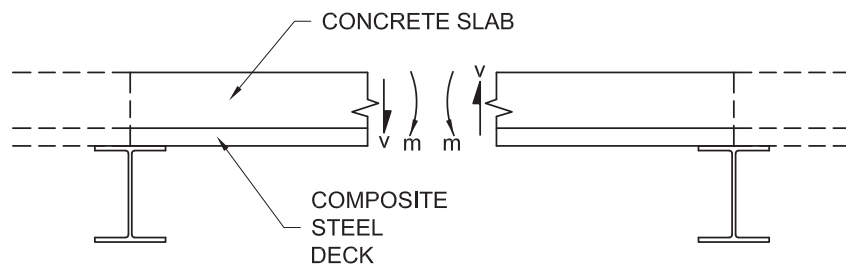

Figure 5.1 Composite Deck-Slab Bending and Shear Strength

The bending strength of the composite deck-slab developed using any of the methods in SDI C-2017 uses the steel deck as the tension reinforcement on the bottom of the composite steel deck-slab.

This is very effective in resisting positive bending between supports. The steel deck does not provide tension resistance to bending over the supports in negative bending. The minimum reinforcement for temperature and shrinkage is not adequate to develop negative bending over supports, therefore the composite deck-slab is treated as a series of simple spans as shown in Figure 5.2. It is possible to design a multi-span composite steel deck-slab when reinforcing steel is added to the concrete to develop negative bending over supports following the provisions of ACI 318.

5.1 Vertical Uniform Loads

Uniform vertical load on composite steel deck is commonly referred to as superimposed load, or the load the deck-slab can support in addition to its self-weight, as determined based on the bending and shear strength of the composite deck slab.

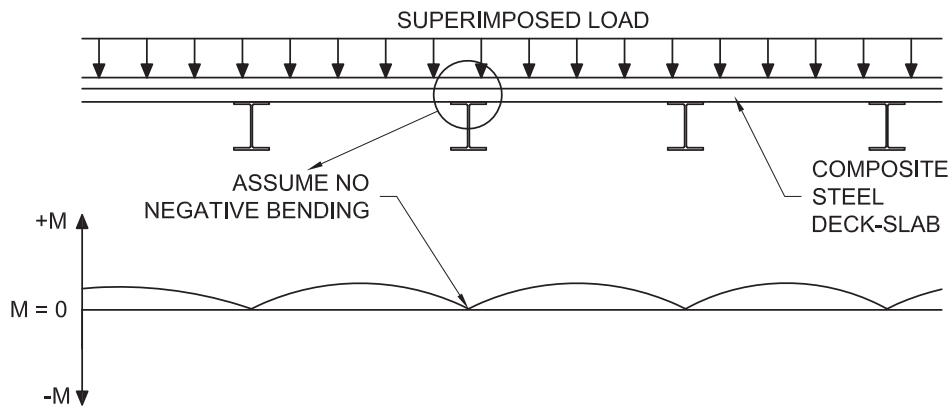

Figure 5.2 Superimposed Load on Steel Deck

Dramix steel fiber provides excellent shear reinforcement and modest flexural reinforcement. The typical required moment in negative bending for thin composite steel deck-slabs generally exceeds the design moment for the Dramix steel fiber reinforced concrete, therefore Dramix is not commonly used to develop a multi-span composite steel deck-slab design.

The maximum design superimposed load for a single span condition is determined using a dead load factor of 1.2 with the SDI yield method for bending and SDI method for vertical shear. The condition presented below is for unshored construction. Shored construction requires that the load effects of shoring removal be considered.

Maximum design superimposed load controlled by bending strength.

$$w = \frac{8\phi_b M_n}{2l} - 1.2w_1$$

Maximum design superimposed load controlled by vertical shear.

$$w = \frac{2\phi_v V_n}{l - 1.2w_1}$$

Where:

l = Composite steel deck-slab span

M_n = Nominal bending strength of composite steel deck-slab

V_n = Nominal vertical shear strength of composite steel deck-slab

$$W_1 = W_{dd} + W_c$$

w_{dd} = weight of steel deck

w_c = weight of concrete

ϕ_b = Resistance factor for composite steel deck-slab bending

ϕ_v = Resistance factor for composite steel deck-slab vertical shear

Maximum superimposed service load based on an L/360 deflection limit.

$$w_{360} = \frac{384EI_d}{360 \cdot 5l^3}$$

Where:

w = maximum design superimposed load

E = Modulus of elasticity for cold-formed steel

I_d = Moment of inertia for deflection of composite steel deck-slab section transformed to steel

l = Composite steel deck-slab span

w_{360} = maximum superimposed service load at L/360

5.2 Vertical Concentrated Loads

Virtually all composite steel deck-slabs will be subject to some magnitude of concentrated loads during the life of the structure. Dramix steel fiber enhances the vertical shear strength of the composite steel deck-slab and its modest bending strength is adequate to redistribute concentrated loads to the deck-slab adjacent to the load, enhancing the concentrated load carrying strength of the steel deck-slab.

SDI C-2017 Section 2.4.B.11 Concentrated Loads; provides the design criteria for composite steel-deck slabs supporting concentrated loads. The section provides a method to laterally distribute a concentrated load to adjacent ribs of the steel deck. This in effect engages a width of the steel deck-slab that is wider than the load to resist the concentrated load. This redistribution requires the concrete slab to have some reinforcing to resist being stressed in the weak direction perpendicular to the ribs of the steel deck. This can be accomplished with Dramix steel fiber reinforced concrete. The redistribution effect is depicted by the bell-curve lines shown in Figure 5.3.

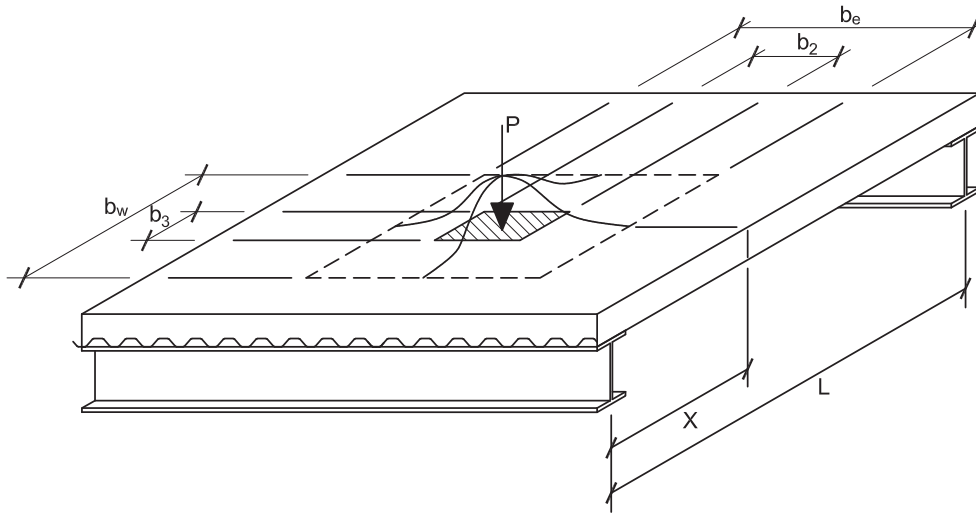

Figure 5.3 Composite Deck-Slab Concentrated Load Redistribution

5.2.1 Load Distribution for Strong Axis Bending

To determine the effective width perpendicular to the ribs of the steel deck, the composite deck-slab projected width, b_m , for the concentrated load as shown in Figure 5.4 is first determined.

$$b_m = b_2 + 2t_c + 2t_t \quad \text{C-2017 Eq. 2.4.10}$$

The effective width, b_e , of the concentrated load perpendicular to the span of the deck as shown in Figure 5.3 is determined using the projected width, load location, and deck-slab span between supports.

For single span bending

$$b_e = b_m + 2 \left(1 - \frac{x}{L}\right) x \leq 106.8 \left(\frac{t_c}{h}\right) \quad \text{C-2017 Eq. 2.4.11}$$

For multi-span bending

$$b_e = b_m + \frac{4}{3} \left(1 - \frac{x}{L}\right) x \leq 106.8 \left(\frac{t_c}{h}\right) \quad \text{C-2017 Eq. 2.4.12}$$

For shear

$$b_e = b_m + \left(1 - \frac{x}{L}\right) x \leq 106.8 \left(\frac{t_c}{h}\right) \quad \text{C-2017 Eq. 2.4.13}$$

Where:

- b_e = Effective width of concentrated load, perpendicular to the deck ribs, in.
- b_m = Projected width of concentrated load, perpendicular to the deck ribs, measured at top of steel deck as shown in Figure 5.4, in.
- b_2 = Width of bearing perpendicular to the deck ribs, in.
- h = Depth of composite deck-slab, measured from bottom of steel deck to top of concrete slab, in.
- L = Deck span length, measured from centers of supports, in.

- t_c = Thickness of concrete above top of steel deck, in.
- t_t = Thickness of rigid topping above structural concrete (if any), in.
- x = Distance from center of concentrated load to nearest support, in.

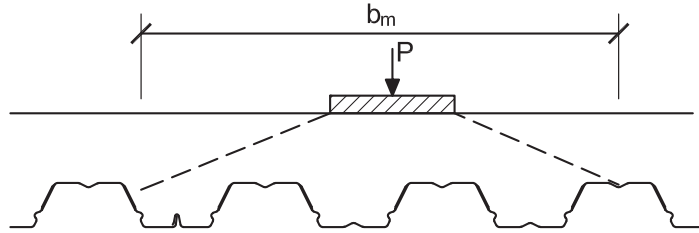

Figure 5.4 Composite Deck-Slab Concentrated Load Projected Width

5.2.2 Load Distribution for Weak Axis Bending

The effective length, b_w , for the concentrated load parallel with the ribs of the steel deck as shown in Figure 5.3, is determined based on the bearing length and span length.

$$b_w = \frac{L}{2} + b_3 \leq L \quad \text{C-2017 Eq. 2.4.14}$$

Where:

b_3 = Length of bearing parallel to the deck ribs, in.

5.2.3 Weak Axis Bending Moment

The weak axis bending moment, M_{weak} , required to distribute the concentrated load over effective width, b_e , perpendicular to the ribs of the steel deck, is based on the load and effective width and length perpendicular and parallel with the ribs of the steel deck.

$$M_{wa} = \frac{12P \cdot b_e}{15b_w}, \text{ in-lbs/ft} \quad \text{C-2017 Eq. 2.4.15a}$$

Where:

L = Deck span length, measured from centers of supports, in.

P = Magnitude of concentrated load, lbs

b_e = Effective width of concentrated load, perpendicular to the deck ribs, in.

b_w = Effective length of concentrated load, parallel to the deck ribs, in.

5.2.4 Load Distribution for Punching Shear

The effective shear perimeter need not approach closer than half the concrete thickness above the deck to the edge of the applied load.

ANSI/SDI C-2017 Section 2.4.B.10

The critical section shall be located so that the perimeter b_o is a minimum, but need not be closer than $h_c/2$ to the periphery of the concentrated load or reaction area.

$$b_o = 2(b_2 + t_c) + 2(b_3 + t_c)$$

Where:

b_2 = Width of bearing perpendicular to the deck ribs, in.

b_3 = Length of bearing parallel to the deck ribs, in.

t_c = Thickness of concrete above top of steel deck, in.

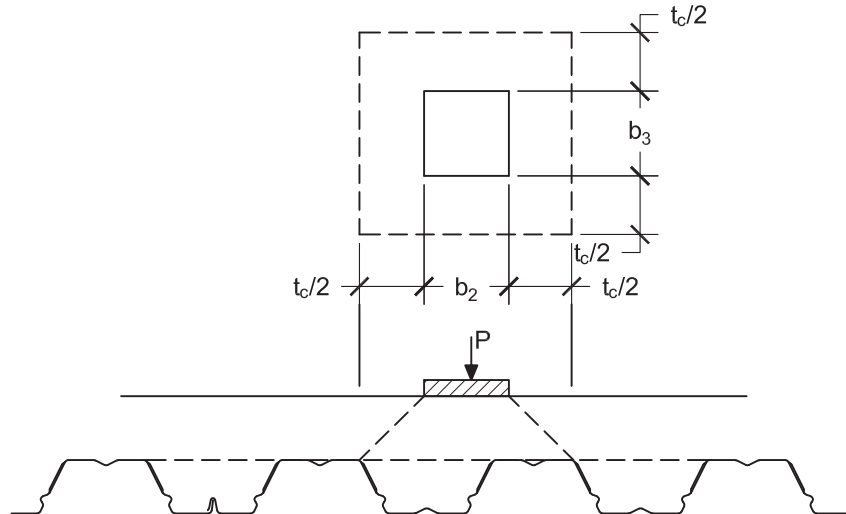

Figure 5.5 Effective Perimeter for Punching Shear

5.3 Composite Steel Deck-Slab Strength

The bending strength in both the strong and weak direction of the composite steel-deck slab must exceed the required strength. This involves the composite steel deck-slab acting as a beam in the strong direction, spanning between the supports, weak axis bending of the concrete slab to distribute the concentrated load, and punching shear through the steel deck-slab at the point of the load.

5.3.1 Composite Steel Deck-Slab Strong Axis Bending Strength and Vertical Shear

For Verco composite deck, the steel deck-slab strength is determined in accordance with SD C-2017 using the bond factor for the appropriate steel deck profile presented in the IAPMO ER-2018.

Bending strength

$$\bar{M} \leq \phi M_{no}$$

Vertical shear strength

$$\bar{V} \leq \phi V_n$$

Where:

ϕM_{no} = Design moment strength of the composite steel deck-slab

ϕV_n = Design vertical shear strength of the composite steel deck-slab

The strength of Verco composite steel deck-slabs, following ER-2018 can be determined using Verco's web-based Composite Steel Deck-Slab Strength design tool. This tool provides a summary page of vertical superimposed loads, maximum unshored construction spans, and composite steel deck-slab properties including strength.

Verco Composite Deck-Slab Strength web-tool:

<https://vulcraft.com/Verco/CompositeDeckSlabStrength>

5.3.2 Steel fiber Reinforced Concrete Weak Axis Bending Strength

The weak axis bending design strength of the reinforced concrete must meet or exceed the required weak axis bending strength, M_{weak} , for load distribution over the effective width perpendicular to the ribs. The strength of the Dramix steel fiber reinforced concrete is suitable for this application. The weak axis bending strength of the reinforced concrete may be developed using Dramix steel fiber reinforced concrete in lieu of traditional welded wire fabric or reinforcing steel following ACI-318 requirements. The bending strength of the Dramix steel fiber is derived from the methods presented in IAPMO Product Approval Report ER-465 Section A4.2.1.1(a) Flexural Model I.

$$M_{weak} \leq \phi M_n$$

Where:

ϕM_n = Design bending strength of the reinforced concrete in the weak direction, perpendicular to the ribs of the steel deck.

The strength of the steel fiber reinforced concrete is derived from the strain and stress diagrams in Figure 5.6.

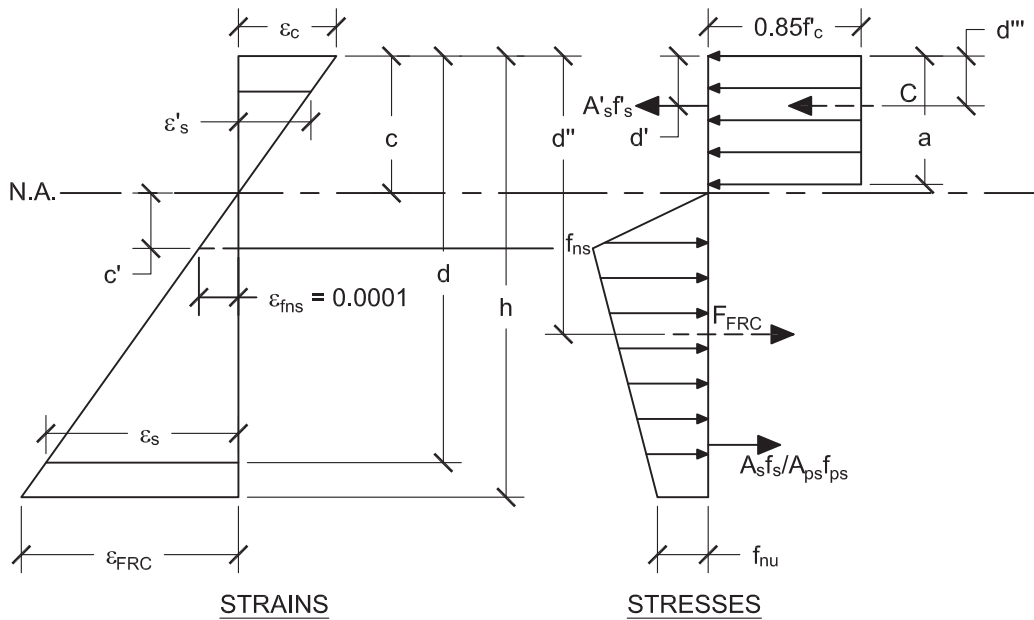

Figure 5.6 Steel fiber Reinforced Concrete Stress and Strain Diagram for Member in Flexure

The depth of the neutral axis and f_{ns} are derived using the strain and stress diagram Figure 5.6, and the concrete compression block follows the provisions of ACI 318 for a flexural member.

Dramix steel fiber reinforced concrete tension strength is based on the fiber stress equation for Verco composite steel deck-slabs with Dramix steel fiber reinforced concrete presented in IAPMO ER-2018.

$$f_{r1}, f_{r4} = C_1 \cdot \left(\frac{D}{\sqrt{f'_c}} \right)^2 + C_2 \cdot \left(\frac{D}{\sqrt{f'_c}} \right)$$

ER-2018 Eq. BD-1

Where:

C_1 = Coefficient

C_2 = Coefficient

D = Fiber dosage, pcy

f'_c = Design strength of concrete, psi ≥ 2500 psi

The nominal axial tensile strength, f_{ns} , corresponding to the strain of 0.0003. ER-465 §A3.2

For $f_{r4} / f_{r1} < 0.7$

$$f_{ns} = 0.37K_oK_sK_c f_{r4}$$

ER-465 Eq. A3-7a

For $f_{r4} / f_{r1} \geq 0.7$

$$f_{ns} = 0.40K_oK_sK_c f_{r1}$$

ER-465 Eq. A3-7b

The nominal axial tensile strength, f_{nu} , corresponding to the strain of 0.025 in accordance with IAPMO ER-465 §A3.2

$$f_{nu} = \alpha_c K_o K_s K_c f_{r4} \quad \text{ER-465 Eq. A3-8}$$

Where:

$$\alpha_c = \text{conversion factor} \quad \text{ER-465 §A3.2}$$

$$= 0.25 \text{ for } f_{r4} / f_{r1} < 0.7$$

$$= 0.25 + (f_{r4} / f_{r1} - 0.7)/3 \text{ for } 0.7 \leq f_{r4} / f_{r1} < 1.0$$

$$= 0.35 + 0.9(f_{r4} / f_{r1} - 1.0)/5 \text{ for } 1.0 \leq f_{r4} / f_{r1} < 1.5$$

$$= 0.44 \text{ for } f_{r4} / f_{r1} \geq 1.5$$

$$K_c = \text{Structural use factor} \quad \text{ER-465 §A3.2}$$

$$= 0.85 \text{ for strength of structural members}$$

$$K_o = \text{Steel fiber orientation factor} \quad \text{ER-465 §A3.2}$$

$$= 1.0 \text{ for slabs}$$

$$K_s = \text{FRC member size factor} \quad \text{ER-465 §A3.2}$$

$$= 1.0 \text{ for slabs}$$

5.3.3 Steel Deck-Slab Punching Shear Strength

The last consideration in design that generally does not govern is to check the composite steel-deck slab for punching shear as shown in Figure 5.5. The shear contribution for Dramix steel fiber is determined following the provisions of IAPMO ER-465 for steel fiber reinforced concrete in shear.

SDI C-2017 specifies the punching shear design methods which are based on ACI-318 two-way shear for normal weight concrete, although that is not explicitly stated. The C-2017 punching shear equation dropped the lightweight concrete factor and does not include the third, equation (c) from ACI 318-14 Section 22.6.5.2. The following equations have the lightweight concrete factor, λ , added in and include all the three limit states from ACI 318-14.

$$V_{pr} = \phi_v V_c$$

$$V_c = \frac{(2 + \frac{4}{\beta_c}) \lambda \sqrt{f'_c} b_o h_c}{1000} \leq \frac{4 \lambda \sqrt{f'_c} b_o h_c}{1000}$$

C-2017 Eq. 2.4.9a
reference ACI 318-14
§22.6.5.2 (a) & (b)

Where:

b_o = Perimeter of critical section, in.

f'_c = Specified compressive strength of concrete, psi

h_c = Thickness of concrete cover above steel deck, in.

V_c = Nominal punching shear resistance, kips

V_{pr} = Design punching shear resistance, kips

β_c = Ratio of long side to short side of concentrated load or reaction area

λ = Lightweight concrete factor from ACI 318-14

ϕ_v = 0.75 from SDI C-2017

An additional check for punching shear in ACI 318-14 not specifically addressed in SDI C-2017 is also considered. The stress corresponding to nominal two-way shear strength provided by concrete, v_c , in psi.

$$v_c \leq \left(2 + \frac{\alpha_s h_c}{b_o}\right) \lambda \sqrt{f'_c} \quad \text{ACI 318-14 §22.6.5.2 (c)}$$

$$V_c \leq \frac{\left(2 + \frac{\alpha_s h_c}{b_o}\right) \lambda \sqrt{f'_c} b_o h_c}{1000}$$

For Dramix steel fiber reinforced concrete, the two-way shear strength is the combination of the shear contribution of the concrete and the additional shear strength of the Dramix steel fiber.

Punching shear including the strength of Dramix steel fiber.

$$v_n = v_c + 1.1v_{FRC} \quad \text{ER-465 Eq. A4-9}$$

Nominal shear strength provided by Dramix steel fiber reinforced concrete is limited to be no greater than 40% of the concrete shear strength.

$$v_{FRC} \leq 0.4v_c \quad \text{ER-465 §A4.2.2.2(a)}$$

Where:

h = Depth of composite deck-slab, measured from bottom of steel deck to top of concrete slab, in.

b = 12 in./ft unit width

The design punching shear strength for the Dramix steel fiber reinforced concrete.

$$\phi_v V_n$$

Where:

$$\phi_v = 0.75$$

The additional strength contribution of the Dramix steel fiber reinforcement resisting punching shear is determined following the provisions of IAPMO ER-465 Section 4.2.2.2 for Two-Way Shear.

Dramix steel fiber reinforced concrete strength.

$$v_{FRC} = 0.37K_c K_o K_s f_{r4}, \text{ psi} \quad \text{ER-465 Eq. A4-8}$$

$$f_{r4} = C_1 \cdot \left(\frac{D}{\sqrt{f'_c}}\right)^2 + C_2 \cdot \left(\frac{D}{\sqrt{f'_c}}\right) \quad \text{ER-2018 Eq. BD-1}$$

Where coefficients C1 and C2 are presented in Table 3.1

Where:

C_1	= Coefficient	ER-2018 Eq. BD-1
C_2	= Coefficient	ER-2018 Eq. BD-1
D	= Steel fiber dosage, pcy	
f'_c	= Design strength of concrete, psi	
K_c	= Structural use factor = 0.85 for strength of structural members	ER-465 §A3.2.1
K_o	= Steel fiber orientation factor = 1.0 for slabs	ER-465 §A3.2.1
K_s	= FRC member size factor = 1.0 for slabs	ER-465 §A3.2.1

Example 5.1

Design the composite steel deck-slab from Example 4.1 for a 2000 lb concentrated load applied over a 4-1/2 in. x 4-1/2 in. area. The load is applied at mid-span of a 10 ft span condition. Assume the clear span is 9 ft as shown in Figure 5.7. This concentrated load will be applied in combination with the deck-slab self-weight, 10 psf superimposed uniform dead load, 80 psf uniform superimposed live load, and vertical seismic load effects. For this project the seismic design parameter, $S_{DS} = 1.15$.

(From Example 4.1)

20 ga W3-36 FormLok deck with

6-1/4 inch, 110 pcf LWC, $f'_c = 3000$ psi, and

35 pcy Dramix 4D 65/60 BG steel fiber

Superimposed Loads:

D = 10 psf

P = 2000 lbs concentrated load

L = 80 psf

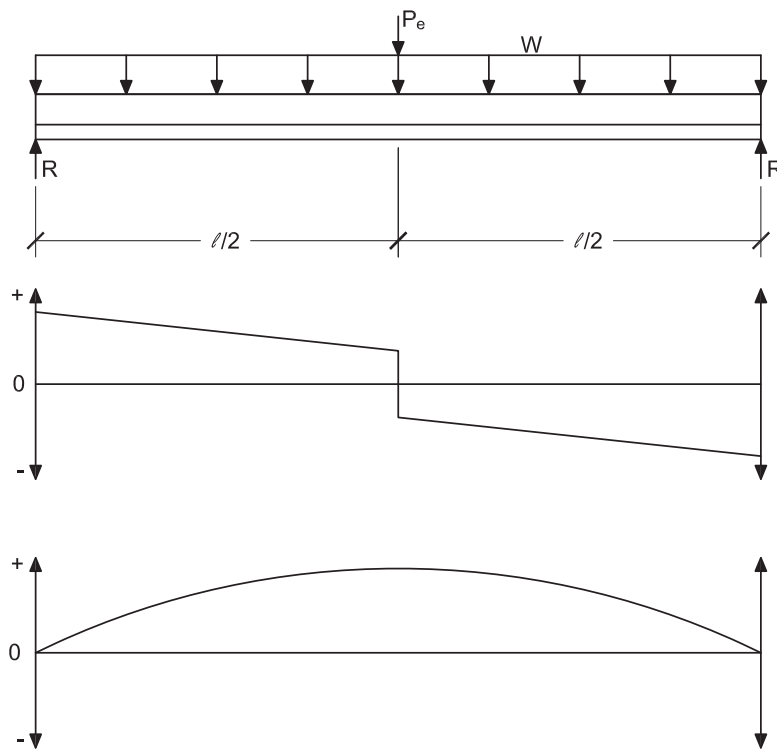
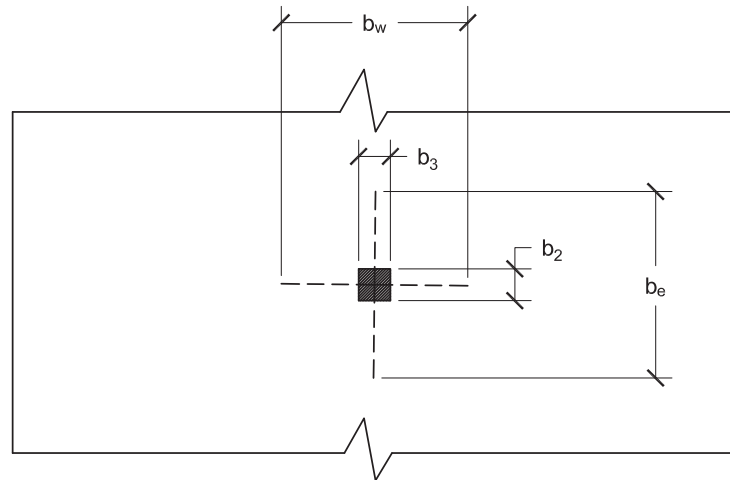

Figure 5.7 Example 5.1 Configuration

To determine the solution to this problem, the self-weight of the steel deck-slab will need to be determined. This can be calculated based on the weight of the steel deck, the profile geometry, slab thickness, and unit weight of the concrete, or by using the Verco Composite Steel Deck-Slab Strength web-based design tool to determine the weight of the steel deck-slab. This web-tool also provides the design moment strength, design vertical shear strength, and section properties for the composite steel deck-slab that will be used through this example. The summary output page is shown in Figure 5.8 with the 20 gage properties outlined. Complete detailed calculations of the properties and superimposed loads presented in the summary page can be generated by the web-tool for verification of the tables.

From the summary sheet in Figure 5.8.

$$W_1 = 45.8 \text{ psf}$$

PLW3-36 FormLok® Composite Steel Deck-Slab (LRFD)

with 6.25 in. 110 pcf 3000 psi LWC



Maximum Unshored Span

Gage	1 Span	2 Span	3 Span
22	10'-0"	10'-0"	10'-11"
21	10'-11"	11'-6"	11'-10"
20	11'-8"	12'-3"	12'-7"
19	12'-2"	13'-7"	14'-1"
18	12'-6"	14'-9"	14'-8"
16	13'-3"	16'-5"	15'-6"

Maximum Unshored Span based on:

Uniform Construction Load	20.00	psf	Minimum End Bearing	3.00	in.
Concentrated Construction Load	150.00	plf	Minimum Interior Bearing	5.50	in.
Concrete Ponding Allowance	2.00	psf	Maximum Deflection L/	180	≤ 0.75 in.
Concrete Volume	1.47	yd ³ / 100 ft ²	(Note: Does not include allowance for ponding)		

Composite Steel Deck Properties (steel deck only)

Gage	Fy ksi	wdd psf	Se+ in. ³ /ft	Se- in. ³ /ft	Id+ in. ⁴ /ft	Id- in. ⁴ /ft	φVn kip/ft
22	50	1.90	0.393	0.410	0.736	0.730	2.074
21	50	2.10	0.453	0.470	0.824	0.817	2.785
20	50	2.30	0.510	0.528	0.907	0.899	3.587
19	50	2.70	0.636	0.652	1.067	1.061	5.030
18	50	2.90	0.752	0.768	1.213	1.211	6.515
16	50	3.50	0.968	0.966	1.516	1.516	9.422

Superimposed Design Load, φWn, / Deflection at L/360 ,psf¹

Gage	8'-0"	9'-0"	10'-0"	11'-0"	12'-0"	13'-0"	14'-0"	15'-0"	16'-0"
22	723/917	560/644	443/469	356/353	291/271	240/213	199/171	166/139	139/114
21	793/950	615/667	487/486	393/365	322/281	266/221	222/177	186/144	157/118
20	858/979	666/688	529/501	427/376	350/290	290/228	243/182	204/148	173/122
19	990/1038	770/729	613/531	497/399	409/307	340/242	285/193	241/157	205/129
18	1112/1092	867/767	692/559	562/420	463/323	386/254	325/203	276/165	236/136
16	1355/1194	1059/838	847/611	690/459	571/353	478/278	404/222	345/181	296/149

Notes: ¹ For high loads, commonly in excess of 325 psf, dynamic or impact loading, and long term concrete creep should be considered. Contact Verco for further assistance.

Composite Steel Deck-Slab Properties

Gage	w ₁ psf	Ic in. ⁴ /ft	Iu in. ⁴ /ft	Id ¹ in. ⁴ /ft	φMno kip-ft/ft	φVno kip/ft	Min. Temperature & Shrinkage	
							As min ² in. ² /ft	or Dramix® Steel Fiber 4D 65/60BG, lbs/cy
22	45.4	6.79	14.71	10.75	6.22	4.79	0.029	29
21	45.6	7.29	14.97	11.13	6.76	5.43	0.029	29
20	45.8	7.74	15.21	11.48	7.31	6.15	0.029	29
19	46.2	8.64	15.71	12.17	8.37	7.44	0.029	29
18	46.4	9.43	16.16	12.79	9.35	7.83	0.029	29
16	47.0	10.92	17.06	13.99	11.30	7.83	0.029	29

Notes: ¹ Id = (Ic + Iu)/2

² Minimum area of steel for temperature and shrinkage

Tables generated using calculator V3.1 based on ANSI/SDI C-2017 in accordance with 2018 IBC Section 2210.

Figure 5.8 Composite Deck-Slab Strength Summary Page



To determine the maximum required moment, the effective width that the concentrated load is distributed over is determined. Figure 5.9a depicts the concentrated load distributed over the bearing width of 4.5 inches. This load will be distributed across the effective width perpendicular to the flutes as shown in Figure 5.9b. The resulting equivalent line load from the concentrated load can then be combined with the uniform load on a per foot width basis to resolve the maximum moment and vertical shear for the governing load combination.

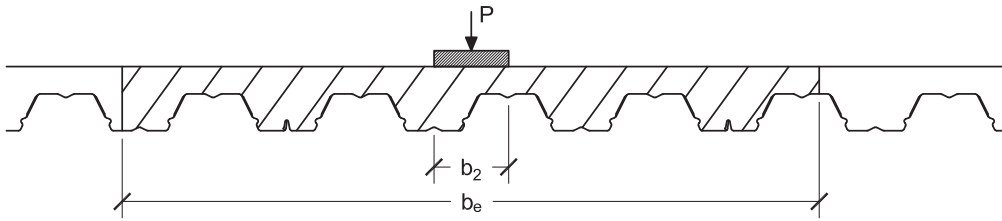

Figure 5.9a

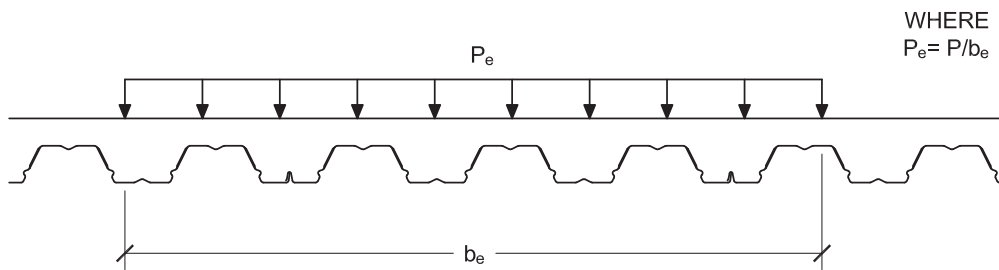

Figure 5.9b

Projected width of concentrated load perpendicular to the ribs.

$$b_m = b_2 + 2t_c + 2t_t$$

C-2017 Eq. 2.4.10

Where:

$$b_2 = 4.5 \text{ in.}$$

$$t_c = 6.25 \text{ in.} - 3 \text{ in.} = 3.25 \text{ in.}$$

$$t_t = 0 \text{ in.}$$

$$b_m = 4.5 + 2 \cdot 3.25 + 2 \cdot 0 = 11 \text{ in.}$$

Effective width for bending, for a single span, of concentrated load perpendicular to the span of the deck.

For single span bending.

$$b_e = b_m + 2 \left(1 - \frac{x}{L}\right) x \leq 106.8 \left(\frac{t_c}{h}\right) \quad \text{C-2017 Eq. 2.4.11}$$

Where:

$$L = 9 \text{ ft} = 108 \text{ in. clear span between supports}$$

$$x = 4.5 \text{ ft} = 54 \text{ in.}$$

$$h = 6.25 \text{ in.}$$

$$b_e = 11 + 2 \left(1 - \frac{54}{108}\right) 54 = 65 \text{ in}$$

$$b_e \leq 56 \text{ in.} = 106.8 \left(\frac{3.25}{6.25}\right) \text{ governs}$$

$$b_e = 56 \text{ in.} = 4.67 \text{ ft}$$

Concentrated load distributed over the effective width.

$$P_d = \frac{P}{b_e} = \frac{2000}{4.67} = 432 \text{ lbs/ft}$$

Where:

$$P = 2000 \text{ lbs}$$

To determine the governing required factored moment, each load combination in ASCE 7 needs to be checked for combined uniform and concentrated loads. For this example, strength design Load Combination 2 has been determined to govern.

ASCE 7-16 Load Combination 2 (LRFD)

$$1.2D + 1.6L + 0.5(L_r \text{ or } S \text{ or } R) \quad \text{ASCE 7-16 §2.3.1}$$

Uniform load is comprised of the 45.8 psf deck-slab self-weight, the 10 psf superimposed dead load, and 80 psf live load.

$$1.2(45.8 \text{ psf} + 10 \text{ psf}) + 1.6(80 \text{ psf}) + 0.5(0) = 195 \text{ psf}$$

Concentrated load is the 2000 lb distributed over the effective width of 4.67 ft = 432 lb/ft.

$$1.2(432 \text{ lb/ft}) = 519 \text{ lb/ft}$$

The first strength check is to determine if the composite steel deck-slab has adequate strength to support the combined uniform and concentrated load in bending. Required factored moment for the moment diagram shown in Figure 5.7.

$$\bar{M} = \frac{wl^2}{8} + \frac{Pl}{4} = \frac{195 \cdot 9^2}{8} + \frac{519 \cdot 9}{4} = 3141 \text{ lbs-ft/ft}$$

The design bending strength from the Composite Deck-Slab Strength web-tool in Figure 5.8 of 7310 lb-ft/ft, which is much greater than the required factored moment of 3129 lb-ft/ft therefore the steel deck-slab is adequate to support the concentrated load in bending.

$$\bar{M} = 3129 \text{ lb-ft/ft} \leq 7310 \text{ lb-ft/ft} = \phi M_{no}$$

In addition to the bending strength design for the steel deck between supports, the 1-way shear strength of the steel deck-slab needs to be evaluated at the supports. To start, the effective distribution width for shear is determined.

For shear.

$$b_e = b_m + \left(1 - \frac{x}{L}\right) x \leq 106.8 \left(\frac{t_c}{h}\right) \quad \text{C-2017 Eq. 2.4.13}$$

Where:

$$L = 9 \text{ ft} = 108 \text{ in. clear span between supports}$$

$$x = 4.5 \text{ ft} = 54 \text{ in.}$$

$$h = 6.25 \text{ in.}$$

$$b_e = 11 \left(1 - \frac{54}{108}\right) 54 = 38 \text{ in. governs}$$

$$b_e \leq 56 \text{ in.} = 106.8 \left(\frac{3.25}{6.25}\right)$$

$$b_e = 38 \text{ in.} = 3.17 \text{ ft}$$

Concentrated load distributed over the effective width.

$$P_d = \frac{P}{b_e} = \frac{2000}{3.17} = 632 \text{ lbs/ft}$$

Where:

$$P = 2000 \text{ lbs}$$

To determine the governing required factored shear, each load combination in ASCE 7 needs to be checked for combined uniform and concentrated loads. For this example, strength design Load Combination 2 has been determined to govern.

ASCE 7-16 Load Combination 2 (LRFD)

$$1.2D + 1.6L + 0.5(L_r \text{ or } S \text{ or } R)$$

ASCE 7-16 §2.3.1

Uniform load is comprised of the 45.8 psf deck-slab self-weight, the 10 psf superimposed dead load, and 80 psf live load.

$$1.2(45.8 \text{ psf} + 10 \text{ psf}) + 1.6(80 \text{ psf}) + 0.5(0) = 195 \text{ psf}$$

Concentrated is the 2000 lb distributed over the effective width of 3.17 ft = 631 lb/ft.

$$1.2(631 \text{ lb/ft}) = 758 \text{ lb/ft}$$

The required vertical shear for the composite steel deck-slab at the supports for the combined uniform and concentrated load in bending is determined from the shear diagram shown in Figure 5.7.

$$\bar{V} = \frac{wL}{2} + \frac{Pa}{L} = \frac{195 \cdot 9}{2} + \frac{757 \cdot 4.5}{9} = 1256 \text{ lbs/ft}$$

The design vertical shear strength from the Composite Deck-Slab Strength web-tool in Figure 5.6 of 6150 lb/ft, for the plain concrete and steel deck without the contribution of the Dramix steel fiber which is much greater than the required vertical factored shear of 1256 lb/ft, therefore the steel deck-slab is

adequate to support the concentrated load in bending

$$\bar{V} = 1256 \text{ lb/ft} \leq 6150 \text{ lb/ft} = \phi V_n$$

The vertical shear design presented here does not include the additional strength due to the Dramix steel fiber. This was omitted because 1-way vertical shear rarely governs. If the design shear strength for the deck-slab is exceeded, the additional contribution of the Dramix steel fiber can be added following the provisions of IAPMO ER-465. This is demonstrated for punching shear at the end of this example.

The second strength check is to verify the weak axis bending strength of the Dramix steel fiber reinforced concrete, perpendicular to the ribs, is adequate to distribute the concentrated load across the effective width. For this example, the concrete is reinforced with 35 lbs/cy of Dramix 4D 65/60 BG steel fiber. The strength determination falls outside of the scope of ACI 318, therefore the methods in IAPMO Product Evaluation Report ER-465 will be used for the fiber reinforced concrete design.

Effective length of the concentrated load parallel with the ribs of the steel deck as shown in Figure 5.3.

$$b_w = \frac{L}{2} + b_3 = \frac{108}{2} + 4.5 = 58.5 \text{ in.} \quad \text{C-2017 Eq. 2.4.14}$$

$$L = 108 \text{ in.} \geq 58.5 \text{ in.} = b_e$$

Therefore 58.5 in. governs.

Next the required weak axis bending moment to distribute the concentrated load over effective width, b_e , perpendicular to the ribs of the steel deck is determined. For the weak axis bending, only the concentrated load is considered because this is the distribution stress that causes deflection in the weak direction above that of the uniform load. To determine the governing required factored moment, each load combination in ASCE 7 needs to be checked for combined uniform and concentrated loads. For the weak axis bending, strength design Load Combination 6 has been determined to govern.

ASCE 7-16 Load Combination 6 (LRFD) when $E_n = 0$

$$1.2D + E_v + L + 0.2S \quad \text{ASCE 7-16 §2.3.6}$$

Load Combination 6 includes vertical seismic load, E_v .

$$E_v = 0.2S_{DS}P \quad \text{ASCE 7-16 Eq. 12.4-4a}$$

$$E_v = 0.2 \cdot 1.15 \cdot 2000 = 460 \text{ lb}$$

$$\bar{P} = 1.2(2000) + 460 = 2860 \text{ lb}$$

Concentrated load is the 2000 lb distributed over the effective width of 58.5 in.

Required weak axis moment for single span bending.

$$\bar{M}_{wa} = \frac{12\bar{P} \cdot b_e}{15b_w} = \frac{12 \cdot 2860 \cdot 56}{15 \cdot 58.5} = 2172 \text{ lb} \cdot \text{in./ft} \quad \text{C-2017 Eq. 2.4.15a}$$

The resisting moment will be for the Dramix steel fiber reinforced concrete based on the bending strength of the concrete section above the top of the steel deck with a thickness of 3.25 in.

The height of the neutral axis based on strain analysis.

$\varepsilon_c \leq 0.003$ ultimate concrete strain

$\varepsilon_{frc} = 0.025$

$$c = \frac{\varepsilon_c}{\varepsilon_c + \varepsilon_{frc}} \cdot h_c = \frac{0.003}{0.003 + 0.025} \cdot 3.25 = 0.35 \text{ in.}$$

Concrete compressive stress block in accordance with ACI 318-14.

$$a = \beta_1 c = 0.85(0.35) = 0.30 \text{ in.}$$

ACI 318-14 Eq. 22.2.2.4.1

Where:

$$\beta_1 = 0.85 \quad \text{for } 2500 \leq f'_c \leq 4000$$

ACI 318-14 §22.2.2.4.3

$$d''' = \frac{a}{2} = \frac{0.30}{2} = 0.15$$

Dramix reinforced concrete tension strength.

$$f_{r1} = -81 \cdot \left(\frac{35}{\sqrt{3000}}\right)^2 + 537 \cdot \left(\frac{35}{\sqrt{3000}}\right) = 310 \text{ psi}$$

ER-2018 Eq. BD-1

$$f_{r4} = -127 \cdot \left(\frac{35}{\sqrt{3000}}\right)^2 + 507 \cdot \left(\frac{35}{\sqrt{3000}}\right) = 272 \text{ psi}$$

ER-2018 Eq. BD-1

$$K_c = 0.85$$

ER-465 §A3.2.1

$$K_o = 1.0$$

ER-465 §A3.2.1

$$K_s = 1.0$$

ER-465 §A3.2.1

$$\frac{f_{r4}}{f_{r1}} = \frac{272}{310} = 0.88$$

for $0.7 \leq f_{r4} / f_{r1} \leq 1.0$

$$\alpha_c = 0.25 + \frac{\frac{f_{r4}}{f_{r1}} - 0.7}{3} = 0.25 + \frac{0.88 - 0.7}{3} = 0.31$$

For $f_{r4} / f_{r1} \geq 0.7$

$$f_{ns} = 0.40K_oK_sK_c f_{r1} = 0.40 \cdot 1.0 \cdot 1.0 \cdot 0.85 \cdot 310 = 105 \text{ psi}$$

ER-465 Eq. A3-7b

$$f_{nu} = \alpha_c K_o K_s K_c f_{r4} = 0.31 \cdot 1.0 \cdot 1.0 \cdot 0.85 \cdot 272 = 72 \text{ psi}$$

ER-465 Eq. A3-8

Distance from the neutral axis to f_{ns}

Where:

$\varepsilon_c = 0.0001$, the strain corresponding to f_{ns} using IAPMO ER-465 Flexural Model I.

$$c' = \frac{\varepsilon_{fns}}{\varepsilon_{fns} + \varepsilon_c} \cdot c = \frac{0.0001}{0.0001 + 0.003} \cdot 0.35 = 0.011 \text{ in.}$$

Distance from the top of the steel deck to f_{ns} .

$$c'' = h_c - c - c' = 3.25 - 0.35 - 0.011 = 2.89 \text{ in.}$$

Tension stress block centroid from neutral axis, see Figure 5.10 for areas and distances to neutral axis of the triangle and trapezoid using parallel axis theorem as presented in Table 5.1.

Area	A in. ²	\bar{y} in.	$A\bar{y}$ in. ³
Triangle	0.59	0.007	0.004
Parallelogram	255.7	1.364	349
$\Sigma A =$	256	$\Sigma A\bar{y} =$	349

Table 5.1 Tension Stress Block Summary

Distance from the neutral axis to the centroid of the FRC tension distribution.

$$\bar{y} = \frac{\Sigma A\bar{y}}{\Sigma A} = \frac{349}{256} = 1.36 \text{ in.}$$

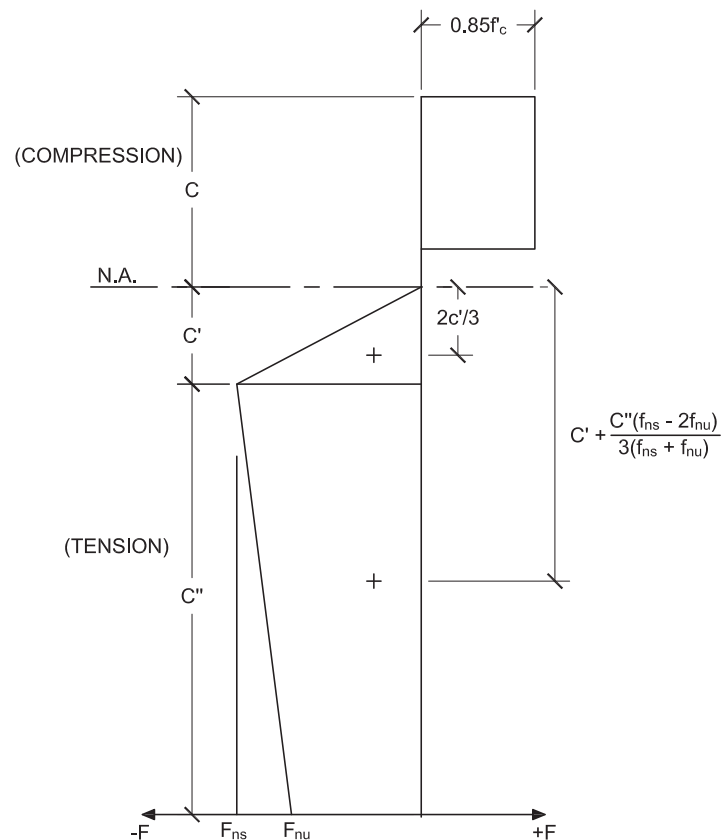

Figure 5.10 FRC Tension Stress Block

Bending strength

$$d'' = c + \bar{y} = 0.35 + 1.36 = 1.71 \text{ in.}$$

$$F_{FRC} = b \sum A = 12 \cdot 256 = 3076 \text{ lbs/ft}$$

$$\phi M_n = \phi_{FRC} F_{FRC} (d'' - d''')$$

ER-465 Eq. A4-2

$$\phi M_n = 0.8 \cdot 3076 \cdot (1.71 - 0.15) = 3842 \text{ lb-in./ft}$$

The weak axis design strength, $\phi M_n = 3842 \text{ lb-in./ft}$, exceeds the required weak axis bending strength, $M_{\text{weak}} = 2190 \text{ lb-in./ft}$, therefore the 35 lbs/cy of Dramix steel fiber is adequate concrete reinforcement.

$$\bar{M}_{\text{weak}} = 2190 \text{ lb-in./ft} \leq 3842 \text{ lb-in./ft} = \phi M_n$$

The third check is for the punching shear through the steel deck-slab due to the concentrated load. Dramix steel fiber reinforces the concrete adding to the shear strength of the concrete.

The effective shear perimeter.

$$b_o = 2(4.5 + 3.25) + 2(4.5 + 3.25) = 31 \text{ in.}$$

Where:

$$b_2 = 4.5 \text{ in.}$$

$$b_3 = 4.5 \text{ in.}$$

$$t_c = 3.25 \text{ in.}$$

The ratio of the long side to the short side of the concentrated load. In this case the sides are equal therefore the ratio is 1.0.

$$\beta_c = \frac{b_2}{b_3} = \frac{4.5}{4.5} = 1.0$$

Design punching shear strength

$$V_c = \frac{\left(2 + \frac{4}{1.0}\right) 0.75 \sqrt{3000} \cdot 31 \cdot 3.25}{1000} = 24.832 \text{ kips} = 24,832 \text{ lbs}$$

C-2017 Eq. 2.4.9a

$$V_c \leq \frac{4 \cdot 0.75 \sqrt{3000} \cdot 31 \cdot 3.25}{1000} = 16.555 \text{ kips} = 16,555 \text{ lbs}$$

C-2017 Eq. 2.4.9a

$$V_c = \frac{\left(2 + \frac{40 \cdot 3.25}{31}\right) 0.75 \sqrt{3000} \cdot 31 \cdot 3.25}{1000} = 25.633 \text{ kips} = 25,633 \text{ lbs}$$

ACI 318-14 §22.6.5.2(c)

Where:

$$\alpha_s = 40 \text{ for interior columns}$$

ACI 318-14 §22.6.5.3

The additional strength contribution of the Dramix steel fiber reinforcement resisting punching shear.

For $d \leq 24$ in

$$v_{FRC} = 0.37K_cK_oK_s f_r^4 \quad \text{ER-465 Eq. A4-7a}$$

$$v_{FRC} = 0.37 \cdot 0.85 \cdot 1.0 \cdot 1.0 \cdot 272 = 85.6 \text{ psi}$$

$$v_{FRC} = v_{FRC} h b_o \quad \text{ER-465 Eq. A4-7}$$

$$v_{FRC} = 85.6 \cdot 3.25 \cdot 31 = 8622 \text{ lbs}$$

$$v_{FRC} \leq 0.4V_c = 0.4 \cdot 16555 = 6622 \text{ lbs governs}$$

Punching shear including the strength of Dramix steel fiber.

$$v_n = v_c + 1.1v_{FRC} = 16555 + 1.1(6622) = 23839 \text{ lbs} \quad \text{ER-465 Eq. A4-9}$$

$$\phi V_n = 0.75 \cdot 23839 = 17879 \text{ lbs}$$

The governing load case for punching is the same as that for the weak axis bending, Load Case 6 of 2860 lb which is well below the punching shear strength of 17,879 lb.

$$\bar{P} = 2860 \text{ lbs} \leq 17879 = \phi V_n$$

Punching shear rarely governs the design. This check for punching shear may be simplified by omitting the contribution of the Dramix steel fiber provided that the punching shear of the plain concrete does not govern the design. If that is the case the more detailed analysis here is warranted.

Based on the three limiting conditions of strong axis bending along the length of the ribs, weak axis bending perpendicular to the ribs, and punching shear, the steel deck-slab with Dramix steel fiber is acceptable to support the concentrated load.