



## NUCOR CORPORATION - VULCRAFT/VERCO GROUP

**VULCRAFT GROUP**  
7205 Gault Avenue North  
Fort Payne, Alabama 35967  
(256) 845-2460  
[www.vulcraft.com](http://www.vulcraft.com)

**VERCO DECKING, INC.**  
a NUCOR Company  
4340 North 42nd Avenue  
Phoenix, Arizona 85019  
(602) 272-1347  
[www.vercodeck.com](http://www.vercodeck.com)

## STEEL DECK PANELS

**CSI Division:** 05 00 00 – METALS  
**CSI Sections:** 05 31 00 – STEEL DECK  
05 31 13 – STEEL FLOOR DECKING  
05 31 23 – STEEL ROOF DECKING

### 1.0 RECOGNITION

Steel deck panels recognized in this report have been evaluated for use as a component of horizontal or sloped floor and roof systems supporting out of plane loads, in-plane diaphragm shears, and in-plane axial loads. Physical characteristics and structural performance properties comply with the intent of the provisions of the following codes and regulations:

- 2021, 2018, 2015 and 2012 International Building Code® (IBC)
- 2021, 2018, 2015 and 2012 International Residential Code® (IRC)
- 2022 California Building Code (CBC) – attached supplement
- 2023 City of Los Angeles Building Code (LABC) – attached supplement
- 2023 City of Los Angeles Residential Code (LARC) – attached supplement

### 2.0 LIMITATIONS

Use of the steel deck panels recognized in this report is subject to the following limitations:

**2.1 Sound Transmission Performance:** Acoustic performance is beyond the scope of this report.

**2.2 Fire-Resistance Ratings:** Fire-resistance performance is beyond the scope of this report.

**2.3** The steel deck panels shall be installed in accordance with the applicable code, the manufacturer's published installation instructions, and this report. Where there is a conflict, the most restrictive requirements shall govern.

**2.4** Calculations and details demonstrating that the loads applied to the steel deck panels comply with this report shall be submitted to the building official for approval. Calculations and drawings shall be prepared, signed, and sealed by a registered design professional where required by the statutes of the jurisdiction in which the project is to be constructed.

**2.5** The steel panels recognized in this report are produced by Vulcraft in Fort Payne, Alabama.

**2.6** The Sammys X-Press Anchors recognized in this report are produced in Elk Grove Village, Illinois.

### 3.0 PRODUCT USE

#### 3.1 General:

Steel deck panels may be designed to resist out-of-plane loads, in-plane diaphragm shear loads, and axial loads.

#### 3.2 Design:

**3.2.1 Out-of-Plane Strength and Deflection:** Out-of-plane strength of steel deck panels shall be determined using engineering mechanics and deck panel properties presented in this report. Steel deck panels shall not be used under conditions subject to loads that are predominately cyclic in nature unless a registered design professional submits substantiating calculations to the building official in accordance with AISI S100-16 (2020) w/S2-20 and AISI S100-16 Chapter M under the 2021 and 2018 IBC and IRC, respectively (AISI S100-07/S2-10 and AISI S100-12 Chapter G under the 2012 and 2015 IBC and IRC, respectively).

Deflections resulting from out-of-plane loads shall comply with Section 1604.3 of the IBC.

**3.2.2 Composite Steel Deck-Slabs:** Composite steel deck-slab out-of-plane load strength (superimposed loads) shall be determined in accordance with ANSI/SDI C using properties and composite coefficients in this report. Use of concrete-filled composite steel deck slabs to support loads that are predominantly vibratory is beyond the scope of this report.

**3.2.3 Composite Beams with Formed Steel Deck:**

Composite beams with formed steel deck included in this report shall be designed in accordance with AISC 360-22 Section I3.2c where the nominal rib height shall not be greater than 3-1/2 in. The strength of steel headed stud anchors used with deck profiles listed in this report shall be determined in accordance with AISC 360-22 Section I8.

**3.2.4 Composite Joists with Formed Steel Deck:**

Composite joists with formed steel deck included in this report shall be designed in accordance with SJI 200-2015 where the nominal rib height shall not be greater than 3-1/2 in. The strength of steel headed stud anchors used with deck profiles listed in this report shall be determined in accordance with SJI 200-2015 Section 4.5.4 where the value  $R_p$  is determined in accordance with AISC 360-22 Section I8.

**3.2.5 Reactions:** The strength of steel deck panels to resist reaction loads at supports and locations of concentrated loads shall be determined based on the either web crippling strength or web shear strength. Web crippling strength shall be determined in accordance with AISI S100-16 (2020) w/S2-20 and AISI S100-16 Section G5 under the 2021 and 2018 IBC and IRC, respectively (AISI S100-07/S2-10 and AISI S100-12 Section C3.4.1 under the 2012 and 2015 IBC and IRC, respectively) and the properties in this report. Deck panel web shear strength of deck panel webs shall be determined in accordance with AISI S100-16 (2020) w/S2-20 and AISI S100-16 Section G2.1 under the 2021 and 2018 IBC and IRC, respectively (AISI S100-07/S2-10 and AISI S100-12 Appendix 1 Section 1.2.2.2.1 under the 2012 and 2015 IBC and IRC, respectively) and the properties in this report. The strength of web-perforated deck panels shall be determined in accordance with the equations in this report.

**3.2.6 In-Plane (Diaphragm) Shear Strength and Stiffness:**

The in-plane shear strength of steel roof deck, non-composite steel deck, or composite steel deck-slabs shall be determined in accordance with AISI S310-16 including the modifications and properties in this report. For steel deck-slabs it is permitted to determine diaphragm shear strength and shear stiffness with the provisions of this report in lieu of AISI S310-16. The steel deck-slab provisions in this report were developed based on full scale reverse cyclic testing.

When steel deck panels are used as the stressed skin shear carrying element of a horizontal or sloped diaphragm as defined in Section 202 of the IBC, the diaphragm length and width shall be limited by one of the following: engineering mechanics, applied loads, shear capacity of the diaphragm, diaphragm shear deflection limited by the requirements of ASCE/SEI 7 in Sections 12.8.6 entitled, "Story Drift Determination", or Section 12.12 entitled, "Drift and Deformation". Shear deflection shall be based on the shear stiffness for the steel deck diaphragm and equations of mechanics.

The use of steel deck diaphragms for vertical diaphragms (shear walls) is beyond the scope of this report.

**3.2.7 Axial Strength:** The axial strength or combined axial and bending strength of steel deck panels shall be determined in accordance with AISI S100 using the properties in this report.

**3.2.8 Wall Bracing:** The design for anchorage of structural walls and transfer of anchorage forces into the diaphragm shall be in accordance with Section 12.11.2 of ASCE/SEI 7, subject to the following limitations:

1. Transfer of anchorage forces into diaphragm shall be in the direction parallel to the flutes (ribs) of the steel deck.

2. When acting as the continuous ties or struts between diaphragm chords, anchorage forces shall be distributed into the diaphragm in the direction parallel to the flutes (ribs) of the steel deck.

3. Combined axial load and bending shall be considered in accordance with Section H1 of AISI S100-16 (2020) w/S2-20 and AISI S100-16 under the 2021 and 2018 IBC and IRC, respectively (Section C5.1 of AISI S100-07/S2-10 and AISI S100-12 under the 2012 and 2015 IBC and IRC, respectively) to determine the strength of steel deck (without concrete fill) used to resist wall anchorage forces or to resist continuous tie forces parallel to the flutes (ribs).

4. Power-actuated fasteners, self-drilling screws, or welded connections described in this report are permitted to provide positive means of attachment to satisfy the connection requirements in ASCE/SEI 7 Section 12.11.2.2.1.

**3.2.9 Partial Panels, Openings, Holes or Penetrations through Steel Deck:** The registered design professional may submit design calculations and details to the building official for approval based on the principles of engineering mechanics for partial panels, openings, holes or penetrations. For lateral force resisting systems, the calculations shall consider the effects of partial panels, openings, holes, or penetrations on the overall strength and stiffness of the diaphragm.

**3.2.10 Supporting Member Materials:** Supporting members shall comply with the requirements of AISI S310-16.

**3.2.11 Bekaert Dramix® Steel Fiber:** Bekaert Dramix steel fibers shall comply with ER-465 and the provisions of this report.

**3.2.11.1 Minimum Temperature and Shrinkage Reinforcement:** For steel deck-slabs, minimum temperature and shrinkage reinforcement dosage utilizing Bekaert Dramix steel fiber shall be determined in accordance with the provisions of this report in lieu of ANSI/SDI C-2017 or ANSI/SDI NC-2017 when used.



### 3.2.12 Connections:

**3.2.12.1 Self-Drilling Screws:** Self-drilling screws may be used to attach steel deck panels to supporting members and to attach the sidelaps of steel deck panels to each other in accordance with AISI S100 and AISI S310 unless described in this report. The screws shall be manufactured in accordance with SAE J78 and shall be compliant with ASTM C1513.

**3.2.12.2 Proprietary Fasteners:** Proprietary screws and power actuated fasteners (PAF's) may be used to attach steel deck panels to supporting members in accordance with this report. The fasteners shall be designed to attach steel deck panels to supporting members and shall be described in a current evaluation report issued by an approved and accredited evaluation service agency.

**3.2.12.3 Welds:** Welds may be used to attach steel deck panels to supporting members and to attach the sidelaps of steel deck panels to each other in accordance with AISI S100 and AISI S310-16. The minimum tensile strength of the weld filler shall be designated as a minimum of 60 ksi (413.7 MPa) and comply with the appropriate AWS standard.

### 3.3 Installation:

Steel deck panel erection sequence and installation method is the responsibility of the contractor(s) performing installation of the steel deck panels. Installation shall be in accordance with this report, ANSI/SDI RD, ANSI/SDI NC and ANSI/SDI C and all welds shall comply with AWS D1.3. Where conflicts occur, the more restrictive shall govern. Additional installation information is available in the Steel Deck Institute (SDI MOC) Manual of Construction with Steel Deck and manufacturer's recommendations. Mechanical fasteners shall be installed in accordance with the manufacturer's current evaluation report issued by an approved and accredited evaluation service agency. Quality control during installation shall comply with ANSI/SDI QA/QC.

### 3.4 Inspections:

**3.4.1 General:** Special inspection is required in accordance with IBC Chapter 17. Quality control and quality assurance for deck installation shall comply with ANSI/SDI QA/QC, where the special inspector duties are as set forth for the quality assurance inspector (QAI). Structural observations shall be provided where required in 2021, 2018 and 2015 IBC Section 1704.6, or 2012 IBC Section 1704.5.

**3.4.2 Jobsite Welding:** Periodic special inspection for welding shall be in accordance with IBC Section 1705.2.2. Prior to proceeding, the welder shall demonstrate the ability to produce the prescribed weld to the special inspector's satisfaction. The inspector's duties include verification of materials, weld preparation, welding procedures, and welding processes.

**3.4.3 Concrete:** Continuous and periodic special inspection for concrete and concrete reinforcement shall be in accordance with Section 1705.3 of the IBC. The inspector's duties include sampling and testing, and verification of concrete mixes, reinforcement types and placement, and concrete placement.

**3.4.4 Seismic-Force-Resisting Systems and Wind-Force-Resisting Systems:** Where the steel deck is used in a seismic-force-resisting system in structures assigned to Seismic Design Category C, D, E or F, periodic special inspections for weld, screw and power-actuated fastener connections are required in accordance with 2021 IBC Section 1705.13.3, 2018 and 2015 IBC Section 1705.12.3 or 2012 IBC Section 1705.11.3.

Where the steel deck is used in a wind-force-resisting system in structures located in areas described in 2021 IBC Section 1705.12, 2018 and 2015 IBC Section 1705.11 or 2012 IBC Section 1705.10), periodic special inspections for weld, screw and power-actuated fastener connections are required in accordance with 2021 IBC Section 1705.12.3, 2018 and 2015 IBC Section 1705.11.3 or 2012 IBC Section 1705.10.3, respectively.

## 4.0 PRODUCT DESCRIPTION

**4.1 Steel Deck Panels:** The steel deck panels described in this report are cold-formed from steel sheets into panels with fluted sections. Panel characteristics including profile designation, sidelap type, applicable sidelap fasteners and perforations for fluted profiles are described in the tables and figures that accompany this report.

The galvanized deck panels are formed from either ASTM A653 or A1063 steel, with a minimum G30 galvanized coating designation.

Vulcraft® and Verco® are registered trademarks of Nucor Corporation or its affiliates.

**4.2 Concrete:** Concrete shall be either lightweight concrete or normal weight concrete and comply with Chapter 19 of the IBC. Calcium chloride or admixtures containing chloride ions shall be limited in accordance with ACI 318-19 19.3.4.1 and 26.4.2.2(g), ACI 318-14 26.4.1.4.1(c), or ACI 318-11 3.6.4. The minimum compressive strength shall be as indicated in the tables and figures of this report.



## 5.0 IDENTIFICATION

Each bundle of deck panels is identified with a visible label. The label includes the manufacturer's name (Vulcraft), production location (Ft. Payne, Alabama), deck type, steel gage and evaluation report number (ER-0423). Either one of the IAPMO UES Marks of Conformity may also be used as noted below.

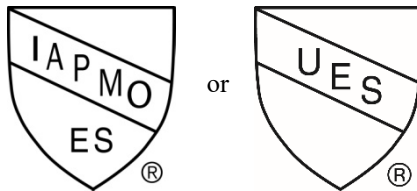

**IAPMO UES ER-0423**

## 6.0 SUBSTANTIATING DATA

Data in accordance with the IAPMO Uniform Evaluation Service Evaluation Criteria EC007-2021, Evaluation Criteria for Steel Composite, Non-composite, and Roof Deck Construction. Test reports are from laboratories in compliance with ISO/IEC 17025.

## 7.0 STATEMENT OF RECOGNITION

This evaluation report describes the results of research completed by IAPMO Uniform Evaluation Service on Vulcraft/Verco Group Steel Floor Decking and Steel Roof Decking. Products are manufactured at locations noted in Section 2.5 and 2.6 of this report under a quality control program with periodic inspection under the supervision of IAPMO UES.

For additional information about this evaluation report please visit [www.uniform-es.org](http://www.uniform-es.org) or email at [info@uniform-es.org](mailto:info@uniform-es.org)



## CALIFORNIA SUPPLEMENT

### REPORT HOLDER NUCOR CORPORATION - VULCRAFT/VERCO GROUP

**VULCRAFT GROUP**  
7205 Gault Avenue North  
Fort Payne, Alabama 35967  
(256) 845-2460  
[www.vulcraft.com](http://www.vulcraft.com)

**VERCO DECKING, INC.**  
a NUCOR Company  
4340 North 42nd Avenue  
Phoenix, Arizona 85019  
(602) 272-1347  
[www.vercodeck.com](http://www.vercodeck.com)

## STEEL DECK PANELS

**CSI Sections: 05 05 23 METAL FASTENINGS**  
**05 31 00 STEEL DECKING**  
**05 31 13 STEEL FLOOR DECKING**  
**05 31 23 STEEL ROOF DECKING**

### 1.0 RECOGNITION

Vulcraft Group and Verco Decking Inc. Steel Deck Panels described in IAPMO UES ER-0423 and this supplement have been evaluated for use as components of floor and roof systems. The structural properties of the steel deck panels were evaluated for compliance with the following codes and regulations:

- 2022 California Building Code (CBC)

### 2.0 LIMITATIONS

Use of the Vulcraft and Verco Steel Deck Panels recognized in this report is subject to the following limitations:

**2.1** Diaphragm deflections shall not exceed the permitted relative deflection of walls between the diaphragm level and the floor below. The flexibility limitations shown in Table 1604A.4 of the California Building Code may be used as a guide in lieu of a rational analysis of the anticipated deflections.

**2.2** As applicable, in accordance with CBC Section 2210A.1.1.2, the minimum base steel thickness of the steel deck shall be 0.0359 inches (0.9 mm), except for single-story open structures, where the steel deck is not used as a diaphragm and there are no suspended hangers or bracing for nonstructural components attached to the deck.

**2.3** Special Inspections are required in accordance with CBC Sections 1705.2 and 1705A.2, Steel Construction; and CBC Sections 1705.3 and 1705A.3, Concrete Construction.

**2.4** Structural Observation is required in accordance with CBC Sections 1704.6 and 1704A.6.

**2.5** Concrete tests and materials shall comply with CBC Sections 1909.2, 1903A, and 1910A, as applicable.

**2.6** This supplement expires concurrently with ER-0423.

**For additional information about this evaluation report, please visit [www.uniform-es.org](http://www.uniform-es.org) or email at [info@uniform-es.org](mailto:info@uniform-es.org)**





## CITY OF LOS ANGELES SUPPLEMENT

### NUCOR CORPORATION - VULCRAFT/VERCO GROUP

**VULCRAFT GROUP**  
7205 Gault Avenue North  
Fort Payne, Alabama 35967  
(256) 845-2460  
[www.vulcraft.com](http://www.vulcraft.com)

**VERCO DECKING, INC.**  
a NUCOR Company  
4340 North 42nd Avenue  
Phoenix, Arizona 85019  
(602) 272-1347  
[www.vercodeck.com](http://www.vercodeck.com)

### STEEL DECK PANELS

CSI Sections: 05 05 23 METAL FASTENINGS  
05 31 00 STEEL DECKING  
05 31 13 STEEL FLOOR DECKING  
05 31 23 STEEL ROOF DECKING

#### 1.0 RECOGNITION

Vulcraft Group and Verco Decking Inc. Steel Deck Panels described in IAPMO UES ER-0423 and this supplement have been evaluated for use as components of floor and roof systems. The structural properties of the steel deck panels were evaluated for compliance with the following codes and regulations:

- 2023 City of Los Angeles Building Code (LABC)
- 2023 City of Los Angeles Residential Code (LARC)

#### 2.0 LIMITATIONS

Use of the Vulcraft and Verco Steel Deck Panels recognized in ER-0423 and this supplement is subject to the following limitations:

**2.1** Design, installation, and inspection shall be in accordance with Chapters 16 and 17 of the LABC, as applicable, due to local amendments to these chapters.

**2.2** Computations and details demonstrating that the loads applied to the decks comply with this report shall be submitted to the Department of Building and Safety for approval. In accordance with LABC Section 106.3.3.2, computations and drawings shall be prepared, stamped, and signed by a California registered design professional for the type of service performed except as otherwise permitted by the Department of Building and Safety.

**2.3** For each job where the deck units are specified, the following information shall be indicated on the plans submitted to the Department of Building and Safety for approval: (a) Cross-section details of the deck panels; (b) fastener details, including deck welding or other fasteners at supports, at diaphragm boundaries parallel to flutes, at shear transfer elements, and at side seams if such fasteners are required; (c) minimum length of deck panels; and (d) design shears.

**2.4** Deck welding shall be performed by Los Angeles City certified cold-formed steel welders. Prior to proceeding with the welding, the welders shall demonstrate to the Deputy Inspectors their ability to produce the prescribed weld satisfactorily. A sample of the deck material shall be welded to steel simulating the framing. The sample specimen shall then be twisted, and if the deck material tears or if the weld in torsion indicates the proper fusion area, the weld shall be considered satisfactory.

**2.5** Admixtures containing calcium chloride or other corrosive materials shall not be used in the concrete mix for the slab.

**2.6** Prior to placement of the concrete for the slab, the steel deck panels shall be cleaned and oil, grease and other materials which may adversely affect the bonding of the concrete to the deck shall be removed.

**2.7** In structures with long term live loads (i.e., warehouses, computer rooms, file rooms, etc.), the allowable loads in the tables of ER-0423 shall be reduced to account for creep in the concrete.

**2.8** This supplement expires concurrently with ER-0423.

**For additional information about this evaluation report, please visit [www.uniform-es.org](http://www.uniform-es.org) or email at [info@uniform-es.org](mailto:info@uniform-es.org)**



## TABLE OF CONTENTS

| Subject   | Page  |
|---|-------|
| Perforated Profiles   | 8     |
| Connections through Perforated Material   | 9     |
| Composite Steel Deck-Slab Coefficient   | 9     |
| Support Connection Tension Flexibility  | 9     |
| Support Connection Shear Rupture Strength   | 9     |
| Diaphragm Shear Strength and Stiffness  | 10    |
| Diaphragm Shear Strength and Stiffness of Structural Concrete Filled Steel Deck-Slabs | 11    |
| Proprietary Fasteners   | 12-13 |
| Proprietary Support Fastener Properties   | 14    |
| ITW Buildex SAMMYS X-Press Swivel Head® Connection                                    | 15    |
| Wedge-Nut Hanging Load  | 16    |
| Nominal Strength of #12 Screw thru Perforated Material                                | 17    |
| Nominal Pull-over Strength of #12 Screw thru Solid Material with Slotted Hole         | 17    |
| Definitions of Section Property Symbols   | 18    |
| Section Properties  | 19-34 |
| 2.0D, 2.0D FormLok  | 19    |
| 2.0DA   | 20    |
| 3.5D, 3.5D FormLok  | 21    |
| 3.5DA   | 22    |
| 2.0DS-30, 2.0DS-30 FL   | 23    |
| 2.0DS-30 AC   | 24    |
| 2.0DS-30 ACW  | 25    |
| 2.0DF-30, 2.0DF-30 FL   | 26    |
| 2.0DF-30 AC   | 27    |
| 2.0DF-30 ACW  | 28    |
| 3.5DS-24, 3.5DS-24 FL   | 29    |
| 3.5DS-24 AC   | 30    |
| 3.5DS-24 ACW  | 31    |
| 3.5DF-24, 3.5DF-24 FL   | 32    |
| 3.5DF-24 AC   | 33    |
| 3.5DF-24 ACW  | 34    |



### PERFORATED PROFILES

#### Perforated Web Reduction Factor

The perforated web reduction factor,  $q_s$  is calculated as follows:

$$q_s = 1 - (1 - k) \left( \frac{W_p}{h_w} \right) \quad [\text{Eq. W-1}]$$

$$p_o = 0.9069 \left( \frac{d_p^2}{c_p^2} \right) \quad [\text{Eq. W-2}]$$

$$\begin{aligned} k &= 1 - 2.175p_o \text{ for } p_o < 0.20 \\ k &= 0.9 + p_o^2 - 1.875p_o \text{ for } 0.20 \leq p_o \leq 0.58 \end{aligned} \quad [\text{Eq. W-3}]$$

Where:

$q_s$  = Perforated web reduction factor

$k$  = Ratio of stiffness

$W_p$  = Width of perforated band in web, in.

$h_w$  = Flat dimension of web measured in plane of web, in.

$p_o$  = Percentage of open area

$d_p$  = Diameter of perforation hole, in.

$c_p$  = Perforation hole center-to-center spacing, in.

#### Shear Strength of Profiles with Perforated Webs

The vertical shear strength for profiles with perforated webs shall be calculated as follows:

$$V_{np} = q_s n_w V_n \sin\theta \quad [\text{Eq. W-4}]$$

Where:

$V_{np}$  = Vertical shear strength of profile with perforated web

$n_w$  = Number of webs per foot

$V_n$  = The nominal shear strength of solid web calculated in accordance with AISI S100-16 (2020) w/S2-20 and AISI S100-16 Sec. G2.1 or Sec C3.2.1 of AISI S100-07/S2-10 and AISI S100-12, kips

$\theta$  = Angle between plane of web and plane of bearing surface, deg

#### Web-Crippling Strength of Profiles with Perforated Webs

The web-crippling strength of a perforated web shall be calculated in accordance with AISI S100-16 (2020) w/S2-20 and AISI S100-16 Sec. G5 or Sec C3.4 of AISI S100-07/S2-10 and AISI S100-12 with the following modified equation:

$$P_n = Ct^2 F_y \cdot \sin\theta \cdot \left( 1 - C_R \sqrt{\frac{R}{t}} \right) \left( 1 + C_N \sqrt{\frac{N}{t}} \right) \left( 1 - C_h \sqrt{\frac{h_w}{q_s t}} \right) \quad [\text{AISI S100-16 (2020) w/S2-20 and AISI S100-16 Eq. G5-1 or Eq. C3.4.1-1 of AISI S100-07/S2-10 and AISI S100-12}] \text{ (Modified)}$$

All variables are as defined in AISI S100-16 (2020) w/S2-20 and AISI S100-16 Section G5 or Sec C3.4 of AISI S100-07/S2-10 and AISI S100-12





| CONNECTIONS THROUGH PERFORATED MATERIAL <sup>1</sup> |                     |                             |                        |          |                                |          |
|--|---------------------|-----------------------------|------------------------|----------|--------------------------------|----------|
| Fastener Property                                    | Fastener            | Adjustment Factor, ρ        | Individual Connections |          | Diaphragms                     |          |
|  |                     |                             | Ω (ASD)                | ϕ (LRFD) | Ω (ASD)                        | ϕ (LRFD) |
| Nominal Shear Strength                               | Screw               | 1.00                        | 3.00                   | 0.50     | Per AISI S310-16<br>Table B1.1 |          |
|  | PAF <sup>2</sup>    | $2.76t + 0.58 \leq 1.00$    | 2.75                   | 0.60     |                                |          |
|  | Weld <sup>3</sup>   | $0.99d + 0.05 \leq 1.00$    | 2.80                   | 0.55     |                                |          |
| Nominal Pullover Strength                            | Screw, PAF          | 0.85                        | 3.00                   | 0.50     |                                |          |
| Nominal Tension Strength                             | Weld <sup>2,4</sup> | $0.19tF_u + 0.11 \leq 1.00$ | 3.00                   | 0.50     |                                |          |
| Flexibility  | Screw               | 1.71                        | -                      |          |                                |          |
|  | PAF                 | 1.15                        |                        |          |                                |          |
|  | Weld                | 1.00                        |                        |          |                                |          |

<sup>1</sup> For connections through perforated material, multiply calculated fastener property by appropriate adjustment factor.

<sup>2</sup> t = Base steel thickness of panel (in.)

<sup>3</sup> d = Visible diameter of arc spot weld (in.)

<sup>4</sup> F<sub>u</sub> = Tensile strength of sheet steel (ksi)

### COMPOSITE STEEL DECK-SLAB COEFFICIENT, K

The flexural strength for composite steel floor deck slabs utilizing steel deck panels be designed in accordance with ANSI/SDI C-2017 Section A2.2 where:

$$K = 2.03 - 1.31 \left( \frac{h_c}{h - y_b} \right) \geq K_{min} \quad [\text{Eq. K-1}]$$

Where:

h<sub>c</sub> = Thickness of concrete cover (in.)

h = Total thickness of deck slab (in.)

y<sub>b</sub> = Distance from extreme bottom fiber to neutral axis of gross section (in.)

K<sub>min</sub> = Minimum composite steel-deck slab coefficient per section property tables

### SUPPORT CONNECTION TENSION FLEXIBILITY

The flexibility of support connection in tension shall be determined in accordance with Eq. T-1:

$$S_t = 1 / (1706 \cdot t^2 \cdot d_w + 2.51) \quad [\text{Eq. T-1}]$$

Where:

S<sub>t</sub> = Structural support connection tension flexibility (in/k)

d<sub>w</sub> = Diameter of support connection or fastener (in.)

t = Base steel thickness of panel (in.)

### SUPPORT CONNECTION SHEAR RUPTURE STRENGTH

The support connection shear rupture strength for the steel deck shall be determined in accordance with Eq. R-1:

$$P_{nv} = 2 \cdot F_u \cdot t \cdot (e - d/2) \quad \Omega = 2.75 \text{ (ASD)} \quad \phi = 0.60 \text{ (LRFD)} \quad \phi = 0.60 \text{ (LSD)} \quad [\text{Eq. R-1}]$$

Where:

P<sub>nv</sub> = Nominal support connection shear rupture strength

F<sub>u</sub> = Tensile strength of sheet steel (ksi)

t = Base steel thickness of panel (in.)

e = Distance between center of connection and edge of sheet (parallel to force) (in.)

d = Visible weld diameter or fastener shank diameter (in.)



### DIAPHRAGM SHEAR STRENGTH AND STIFFNESS

Diaphragm shear strength and stiffness shall be calculated per AISI S310-16 with the following modifications:

#### **D1 Diaphragm Shear Strength per Unit Length Controlled by Connection Strength, $S_{nf}$**

The nominal shear strength [resistance] per unit length of a diaphragm controlled by connection strength,  $S_{nf}$ , shall be the smallest of  $S_{ni}$ ,  $S_{nc}$ ,  $S_{ne}$ , and  $S_{np}$ .

$$S_{np} = \text{minimum} \left( n_d P_{nf} \frac{1}{w_t} \right) \quad [\text{Eq. D1-4}]$$

Where

$S_{np}$  = Nominal shear strength [resistance] per unit length of diaphragm controlled by connections along the edge perpendicular to the panel span and located at exterior support

$n_d$  = Number of support connections at any given bottom flute along a panel end perpendicular to the panel span and located at exterior support

$w_t$  = Greatest tributary width to any given bottom flute with support connections along the edge perpendicular to the panel span and located at exterior support

*All other variables are as defined in AISI S310-16 Section D1*

#### **D2.1 Fluted Panel**

The nominal diaphragm shear strength [resistance] per unit length,  $S_{nb}$ , for either acoustic or non-acoustic fluted panels shall be the smallest of  $S_{no}$ , and  $S_{ni}$ .

$$S_{no} = \alpha \frac{7890}{L_v^2} \left( \frac{I_{xg}^3 t^3 d}{s} \right)^{0.25} \quad [\text{Eq. D2.1-1}]$$

$$S_{ni} = P_n \frac{d - e}{D_d} \left( \frac{12}{d} \right) \quad [\text{Eq. D2.1-2}]$$

Where

$\alpha$  = 1.00 for panels fastened to support at every bottom flute at exterior supports  
0.75 for panels not fastened to support at every bottom flute at exterior supports

$S_{no}$  = Nominal diaphragm shear strength [resistance] per unit length controlled by panel out-of-plane buckling, kip/ft

$S_{ni}$  = Nominal diaphragm shear strength [resistance] per unit length controlled by exterior support local web buckling, kip/ft

$d$  = Panel corrugation pitch, in.

$e$  = One-half the bottom flat width of panel measured between points of intercept, in.

$D_d$  = Depth of panel, in.

$$P_n = 4.36t^2 F_y \cdot \sin\theta \cdot \left( 1 - 0.04 \sqrt{\frac{R}{t}} \right) \left( 1 + 0.25 \sqrt{\frac{N_e}{t}} \right) \left( 1 - 0.025 \sqrt{\frac{h_w}{t}} \right) \quad [\text{Eq. D2.1-3}]$$

Where

$t$  = Base steel thickness of panel, in.

$F_y$  = Design yield stress, ksi

$\theta$  = Angle between plane of web and plane of bearing surface, deg.

$R$  = Inside bend radius, in.

$N_e$  = Bearing Length at end of panel support, in.

$h_w$  = Flat dimension of web measured in plane of web, in.

#### **D5.1.1 Stiffness of Fluted Panels**

For spacing of fasteners connecting panels along longitudinal edges parallel to the deck flutes greater than the interior side-lap seam fastener spacing:

$$d_e \leq \frac{S_s}{S_f} d_s \quad [\text{Eq. G}]$$

Where:

$d_e$  = Spacing of parallel edge fasteners

$d_s$  = Spacing of sidelap fasteners

$S_s$  = Sidelap connection flexibility (in/kip)

$S_f$  = Structural support connection flexibility (in/k)



#### **DIAPHRAGM SHEAR STRENGTH AND STIFFNESS OF STRUCTURAL CONCRETE FILLED STEEL DECK-SLABS**

For structural concrete deck-slabs with a concrete thickness above the top of the deck no less than 2 in. or greater than 6 in., the nominal shear strength per unit length of diaphragms with structural concrete fill is calculated in accordance with Eq. C-1 and the diaphragm stiffness is calculated in accordance with Eq. C-4.

$$S_n = S_c + S_f \quad \Omega = 2.00 \text{ (ASD)} \quad \phi = 0.80 \text{ (LRFD)} \quad \phi = 0.70 \text{ (LSD)} \quad [\text{Eq. C-1}]$$

$$S_c = k_c \cdot \lambda \cdot b \cdot \left[ \left( D_c + \frac{D_d}{2} \right) + t \cdot \left( \frac{E}{E_c} \right) \cdot \left( \frac{d}{s} \right) \right] \cdot \sqrt{f'_c} \quad [\text{Eq. C-2}]$$

$$\begin{aligned} \text{For } D \geq 35 \text{ pcy, } S_f &= 0.37 \cdot f_{150} \cdot \left( D_c + \frac{D_d}{2} \right) \quad [\text{Eq. C-3}] \\ \text{For } D < 35 \text{ pcy, } S_f &= 0.00 \end{aligned}$$

$$G' = 4.8 \cdot \left[ \left( D_c + \frac{D_d}{2} \right) + t \cdot \left( \frac{E}{E_c} \right) \cdot \left( \frac{d}{s} \right) \right] \cdot \sqrt{f'_c} \quad [\text{Eq. C-4}]$$

For structural concrete deck-slabs utilizing dovetail deck profiles and Bekaert Dramix 4D 65/60 BG Steel Fibers installed in accordance with IAPMO UES ER-465, steel fiber reinforced concrete properties are determined in accordance with Eq. BD-1

For normal weight concrete, 15 pcy ≤ D ≤ 66 pcy. For light weight concrete, 20 pcy ≤ D ≤ 66 pcy

$$f_{r1}, f_{r4}, f_{150}, R_{T,150}^D = C_1 \cdot \left( \frac{D}{\sqrt{f'_c}} \right)^2 + C_2 \cdot \left( \frac{D}{\sqrt{f'_c}} \right) \quad [\text{Eq. BD-1}]$$

|       | $f_{r1}$ | $f_{r4}$ | $f_{150}$ | $R_{T,150}^D$ |
|-------|----------|----------|-----------|---------------|
| $C_1$ | -81      | -127     | -127      | -30           |
| $C_2$ | 537      | 507      | 507       | 105           |

Bekaert Dramix 4D 65/60 BG required minimum dosage for temperature and shrinkage shall satisfy the requirements of equation BD-2 with a dosage for normal weight concrete, 15 pcy ≤ D ≤ 66 pcy and for light weight concrete, 20 pcy ≤ D ≤ 66 pcy.

$$39.96 \cdot \lambda \cdot \sqrt{f'_c} \cdot D_c \cdot R_{T,150}^D / 100 \geq \max(540 \cdot D_c, 1680 \text{ lbf}) \quad [\text{Eq. BD-2}]$$

Where:

$S_n$  = Nominal shear strength of diaphragm system with concrete fill

$S_c$  = Shear strength of steel deck and structural concrete calculated in accordance with Eq. C-2, k/ft

$S_f$  = Bekaert Dramix steel fiber contribution to shear strength calculated in accordance with Eq. C-3

$G'$  = Shear stiffness of concrete deck-slab diaphragm, k/in

$k_c$  = Factor for structural concrete strength = 3.2/1000

$\lambda$  = 1.00 for normal weight concrete  
= 0.75 for lightweight concrete

$b$  = Unit width of diaphragm with structural concrete fill = 12 in.

$D_c$  = Depth of concrete above steel deck flutes, in.

$D_d$  = Depth of steel deck, in.

$D$  = Fiber dosage, pcy

$t$  = Base steel thickness of panel, in.

$E$  = Modulus of elasticity of steel

$E_c$  = Modulus of elasticity of concrete in accordance with ACI 318

$d$  = Panel corrugation pitch, in.

$s$  = Developed flute width of single corrugation, in.

$f'_c$  = Structural concrete compressive strength, psi ≥ 2500 psi

$f_{r1}$  = Stress corresponding  $CMOD_1$ , psi, as defined in IAPMO UES ER-465

$f_{r4}$  = Stress corresponding to  $CMOD_4$ , psi, as defined in IAPMO UES ER-465

$f_{150}$  = Stress at L/150, psi

$R_{T,150}^D$  = Equivalent flexural stress ratio as defined by IAPMO UES ER-465

All other variables as defined in IAPMO UES ER-465

#### **STRUCTURAL CONCRETE FILLED STEEL DECK-SLAB SHEAR TRANSFER TO CHORDS AND COLLECTORS**

Shear transfer of structural concrete fill deck-slab to chords and collectors shall be in accordance with AISI S310-16 Section D4.4 including D4.4.1 with safety and resistance factors for connections of the composite deck slab to supports as follows:

1. Steel headed stud anchors with nominal shear strength determined in accordance with AISC 360 with the following factors:  
 $\Omega = 3.00 \text{ (ASD)} \quad \phi = 0.55 \text{ (LRFD)} \quad \phi = 0.50 \text{ (LSD)}$
2. Available strength [factored resistance] for welds shall be determined in accordance with AISI S100-16.
3. Available strength [factored resistance] for screws shall be determined in accordance with AISI S100-16.
4. Available strength [factored resistance] for proprietary fasteners shall be determined in accordance with this report,  $\Omega$  and  $\phi$  are listed on Page 13 of this report.



### PROPRIETARY FASTENERS

#### Hilti

The nominal shear strength [resistance] for the Hilti X-ENP-19 L15 PAF shall be determined in accordance with Eq. H-1:

$$P_{nf} = 56 \cdot t \cdot (1 - t) \leq P_{nvp} \quad [\text{Eq. H-1}]$$

The nominal shear strength [resistance] for the Hilti X-HSN24 PAF shall be determined in accordance with Eq. H-2:

$$P_{nf} = 52 \cdot t \cdot (1 - t) \leq P_{nvp} \quad [\text{Eq. H-2}]$$

The flexibility of the Hilti X-ENP-19 L15 shall be determined in accordance with Eq. H-3a:

$$S_f = \frac{0.75}{1000\sqrt{t}} \quad [\text{Eq. H-3a}]$$

The flexibility of the Hilti X-HSN24 PAF shall be determined in accordance with Eq. H-3b:

$$S_f = \frac{1.25}{1000\sqrt{t}} \quad [\text{Eq. H-3b}]$$

The nominal tension strength [resistance] for the Hilti X-HSN 24 controlled by pull-out shall be determined in accordance with Eq. H-4:

$$P_{not} = 8 \cdot t_{\text{support}} + 0.088 \leq 1.875 \quad \Omega = 2.50 \text{ (ASD)} \quad \phi = 0.65 \text{ (LRFD)} \quad \phi = 0.55 \text{ (LSD)} \quad [\text{Eq. H-4}]$$

The nominal tension strength [resistance] for the X-ENP-19 L15 controlled by pull-out shall be determined in accordance with Eq. H-5:

$$P_{not} = 2.625 \quad \Omega = 2.50 \text{ (ASD)} \quad \phi = 0.65 \text{ (LRFD)} \quad \phi = 0.55 \text{ (LSD)} \quad [\text{Eq. H-5}]$$

#### Simpson Strong-Tie

The nominal shear strength [resistance] for the Simpson XL Screw shall be determined in accordance with Eq. S-1:

$$P_{nf} = 78 \cdot t \cdot (t_{\text{support}})^{0.15} \leq P_{nvs} \quad [\text{Eq. S-1}]$$

The nominal shear strength [resistance] for the Simpson XM Screw shall be determined in accordance with Eq. S-2a or S-2b:

$$\text{For } t_{\text{support}} \leq 0.1875 \text{ in} \quad P_{nf} = 240 \cdot (t)^{1.5} \leq P_{nvs} \quad [\text{Eq. S-2a}]$$

$$\text{For } t_{\text{support}} > 0.1875 \text{ in} \quad P_{nf} = 53 \cdot t \leq P_{nvs} \quad [\text{Eq. S-2b}]$$

The nominal shear strength [resistance] for the Simpson X1S1016 or XQ1S1016 shall be determined in accordance with Eq. S-3:

$$P_{ns} = 20 \cdot t \leq 1.625 \quad [\text{Eq. S-3}]$$

The nominal shear strength [resistance] for the Simpson XU34B1016 shall be determined in accordance with Eq. S-4:

$$P_{ns} = 25.2 \cdot t \leq 1.735 \quad [\text{Eq. S-4}]$$

Where:

$t$  = Base steel thickness of panel (in.)

$t_{\text{support}}$  = Thickness of support (in.)

$S_s$  = Sidelap connection flexibility (in/kip)

$S_f$  = Structural support connection flexibility (in/k)

$P_{nf}$  = Nominal shear strength [resistance] of a support connection (kips)

$P_{ns}$  = Nominal shear strength [resistance] of a side-lap connection per fastener (kips)

$P_{nvs}$  = Nominal shear strength [resistance] of screw (see page 13)

$P_{nvp}$  = Nominal shear strength [resistance] of PAF (see page 13)

$P_{not}$  = Nominal tensile strength [resistance] of a support connection per fastener controlled by pull-out (kips)



### PROPRIETARY FASTENERS (Continued)

#### **Pneutek**

The nominal shear strength [resistance] for the Pneutek SDK61 PAF shall be determined in accordance with Eq. P-1a and P-1b:

For substrate thickness equal to 0.113"

$$P_{nf} = 0.735 \cdot t \cdot F_u(1 - 0.016 \cdot t \cdot F_u) \leq P_{nvp} \quad [\text{Eq. P-1a}]$$

For substrate thickness equal to 0.155"

$$P_{nf} = 0.788 \cdot t \cdot F_u(1 - 0.028 \cdot t \cdot F_u) \leq P_{nvp} \quad [\text{Eq. P-1b}]$$

For substrate thickness between 0.113" and 0.155",  $P_{nf}$  shall be determined by interpolation.

The nominal shear strength [resistance] for the Pneutek SDK63, K64 and K66 PAF shall be determined in accordance with Eq. P-2:

$$P_{nf} = 1.264 \cdot t \cdot F_u(1 - 0.053 \cdot t \cdot F_u) \leq P_{nvp} \quad [\text{Eq. P-2}]$$

The flexibility of the Pneutek SDK61 PAF shall be determined in accordance with Eq. P-3:

$$S_f = \frac{3}{1000\sqrt{t}} \quad [\text{Eq. P-3}]$$

The flexibility of the Pneutek SDK63, K64 and K66 PAF shall be determined in accordance with Eq. P-4a and P-4b:

For substrate thickness less than 0.25"

$$S_f = \frac{3}{1000\sqrt{t}} \quad [\text{Eq. P-4a}]$$

For substrate thickness equal to or greater than 0.25"

$$S_f = \frac{1}{1000\sqrt{t}} \quad [\text{Eq. P-4b}]$$

The nominal tension strength [resistance] for the Pneutek SDK61, SDK63, K64 and K66 PAF controlled by pull-out shall be determined in accordance with Eq. P-5:

$$P_{not} = 18.37 \cdot t_{support} \leq 4.811 \quad \Omega = 2.45 \text{ (ASD)} \quad \phi = 0.65 \text{ (LRFD)} \quad \phi = 0.55 \text{ (LSD)} \quad [\text{Eq. P-5}]$$

Where:

$P_{not}$  = Nominal tensile strength [resistance] of a support connection per fastener controlled by pull-out (kips)

$P_{nf}$  = Nominal shear strength [resistance] of a support connection per fastener (kips)

$t$  = Base steel thickness of panel (in.)

$F_u$  = Ultimate strength of sheet steel (ksi)

$P_{nvp}$  = Nominal shear strength [resistance] of PAF (see page 13)

$t_{support}$  = Thickness of support (in.)

$S_f$  = Structural support connection flexibility (in/k)

$\phi$  = Resistance Factor

$\Omega$  = Safety Factor



| PROPRIETARY SUPPORT FASTENER PROPERTIES <sup>1-4</sup>  |  |          |         |  |       |       |  |          |
|---|--|----------|---------|--|-------|-------|--|----------|
| Specified Properties  | Hilti  |          | Pneutek |  |       |       | Simpson Strong-Tie   |          |
|   | X-HSN 24   | X-ENP-19 | SDK61   | SDK63  | K64   | K66   | XM Screw   | XL Screw |
| Minimum Substrate Thickness (in)  | 0.125  | 0.250    | 0.113   | 0.155  | 0.187 | 0.281 | 0.125  | 0.125    |
| Maximum Substrate Thickness (in)  | 0.375  | ∞        | 0.155   | 0.250  | 0.312 | ∞     | 0.610  | 0.610    |
| Shank Diameter (in)   | 0.157  | 0.177    | 0.144   | 0.173  | 0.181 | 0.199 | 0.216  | 0.216    |
| Head or Washer Diameter (in)  | 0.474  | 0.591    | 0.500   | 0.500  | 0.500 | 0.500 | 0.483  | 0.625    |
| Nominal Tensile Strength based on Material strength, P <sub>nts</sub> (kip) <sup>1</sup>        | 5.033<br>Ω = 2.65 (ASD)<br>φ = 0.60 (LRFD)<br>φ = 0.50 (LSD) | 6.397    | 3.909   | 5.641<br>Ω = 2.65 (ASD)<br>φ = 0.60 (LRFD)<br>φ = 0.50 (LSD) | 6.175 | 7.465 | 4.985<br>Ω = 3.00 (ASD)<br>φ = 0.50 (LRFD)<br>φ = 0.40 (LSD) | 4.985    |
| Nominal Shear Strength of Screw based on Material Strength, P <sub>nvs</sub> (kip) <sup>2</sup> | -  | -        | -       | -  | -     | -     | 3.110<br>Ω = 3.00 (ASD)<br>φ = 0.50 (LRFD)<br>φ = 0.40 (LSD) | 3.110    |
| Nominal Shear Strength of PAF based on Material Strength, P <sub>nvp</sub> (kip) <sup>3</sup>   | 3.020<br>Ω = 2.65 (ASD)<br>φ = 0.60 (LRFD)<br>φ = 0.50 (LSD) | 3.838    | 2.345   | 3.385<br>Ω = 2.65 (ASD)<br>φ = 0.60 (LRFD)<br>φ = 0.50 (LSD) | 3.705 | 4.479 | -  | -        |
| Individual Fastener Shear Strength, P <sub>nf</sub> <sup>4</sup>                                | Ω = 2.30 (ASD)<br>φ = 0.70 (LRFD)<br>φ = 0.55 (LSD)          |          |         | Ω = 2.40 (ASD)<br>φ = 0.65 (LRFD)<br>φ = 0.55 (LSD)          |       |       | Ω = 2.30 (ASD)<br>φ = 0.70 (LRFD)<br>φ = 0.55 (LSD)          |          |

<sup>1</sup> Determined in accordance with AISI S100-16 (2020) w/S2-20 and AISI S100-16 Sections J5.2.1 and J4.4.3 or Sections E5.2.1 and E4.4.3 of AISI S100-07/S2-10 and AISI S100-12

<sup>2</sup> Determined in accordance with AISI S100-16 (2020) w/S2-20 and AISI S100-16 Section J4.3.2 or Section E4.3.2 of AISI S100-07/S2-10 and AISI S100-12

<sup>3</sup> Determined in accordance with AISI S100-16 (2020) w/S2-20 and AISI S100-16 Section J5.3.1 or Section E5.3.1 of AISI S100-07/S2-10 and AISI S100-12

<sup>4</sup> For use when calculating individual fastener shear strength in accordance with equations listed on pages 11-12 of this report.

<sup>5</sup> The shear strength of the connection shall be the minimum of the allowable strength for ASD, the design strength for LRFD, or the factored strength for LSD of the individual fastener shear strength and the shear strength based on material strength.





| ITW BUILDEX SAMMYS X-PRESS CONNECTION <sup>1-8</sup> |                             |                |           |                            |                           |  |                              |                           |  |
|--|-----------------------------|----------------|-----------|----------------------------|---------------------------|--|------------------------------|---------------------------|--|
| SAMMYS X-Press Type                                  |                             |                | Deck Gage | Solid Material (Gr. 40)    |                           |  | Perforated Material (Gr. 40) |                           |  |
| Part Number  | Model Number <sup>2-4</sup> | Rod Size (in.) |           | ASD $P_{not}/\Omega$ (lbs) | LRFD $\phi P_{not}$ (lbs) | Max. Fire Sprinkler Pipe Size <sup>9</sup> (in.) | ASD $P_{not}/\Omega$ (lbs)   | LRFD $\phi P_{not}$ (lbs) | Max. Fire Sprinkler Pipe Size <sup>9</sup> (in.) |
| 8181922  | XP 200                      | 1/4            | 22        | 277                        | 441                       | 2  | 194                          | 303                       | 1 1/2  |
| 8150922  | XP 20                       | 3/8            | 20        | 337                        | 535                       | 2 1/2  | 235                          | 368                       | 2  |
| 8294922  | SXP 20                      | 3/8            | 19        | 393                        | 625                       | 2 1/2  | 274                          | 430                       | 2  |
| 8272957  | SXP 2.0                     | 1/2            | 18        | 446                        | 709                       | 3  | 311                          | 488                       | 2 1/2  |
| 8181922  | XP 200                      | 1/4            | 16        | 562                        | 894                       | 4  | 392                          | 615                       | 3  |
| 8153299  | XP 35                       | 3/8            |           |                            |                           |  |                              |                           |  |
| 8295922  | SXP 35                      | 3/8            |           |                            |                           |  |                              |                           |  |
| 8271957  | SXP 3.5                     | 1/2            |           |                            |                           |  |                              |                           |  |

<sup>1</sup> For Solid:  $P_{not} = 0.453 \cdot t \cdot F_u$        $\Omega = 2.65$  (ASD)       $\phi = 0.60$  (LRFD)  
 For Perforated:  $P_{not} = 0.340 \cdot t \cdot F_u$        $\Omega = 2.85$  (ASD)       $\phi = 0.55$  (LRFD)

Where  $P_{not}$  = Nominal pullout strength of SAMMYS X-Press Connector, kips

<sup>2</sup> XP 200 may not be used to support sprinkler pipe.

<sup>3</sup> XP 200, XP 20 and XP 35 shall be installed and loaded perpendicular to the deck surface  $\pm 5^\circ$ .

<sup>4</sup> SXP 20, SXP 2.0, SXP 35 and SXP 3.5 may be installed in any flat portion of the bottom flange.

The load may be applied at any angle,  $\theta$ , from 0 to 90 degrees,  $0^\circ \leq \theta \leq 90^\circ$ , relative to the axis of the base of the connector and any angle,  $\alpha$ , from 0 to 360 degrees,  $0^\circ \leq \alpha \leq 360^\circ$ , relative to the ribs of the steel deck as shown below.

<sup>5</sup> The allowable strength,  $P_n/\Omega$ , shall be equal to or greater than the governing load combination for Allowable Stress Design (ASD) as stipulated in the IBC or ASCE/SEI 7.

<sup>6</sup> The factored strength,  $\phi P_n$ , shall be equal to or greater than the governing load combination for Load and Resistance Factor Design as stipulated in the IBC or ASCE/SEI 7.

<sup>7</sup> Maximum fire sprinkler pipe size in accordance with NFPA 13.

<sup>8</sup> SAMMYS X-Press shall be installed per manufacturers instructions.

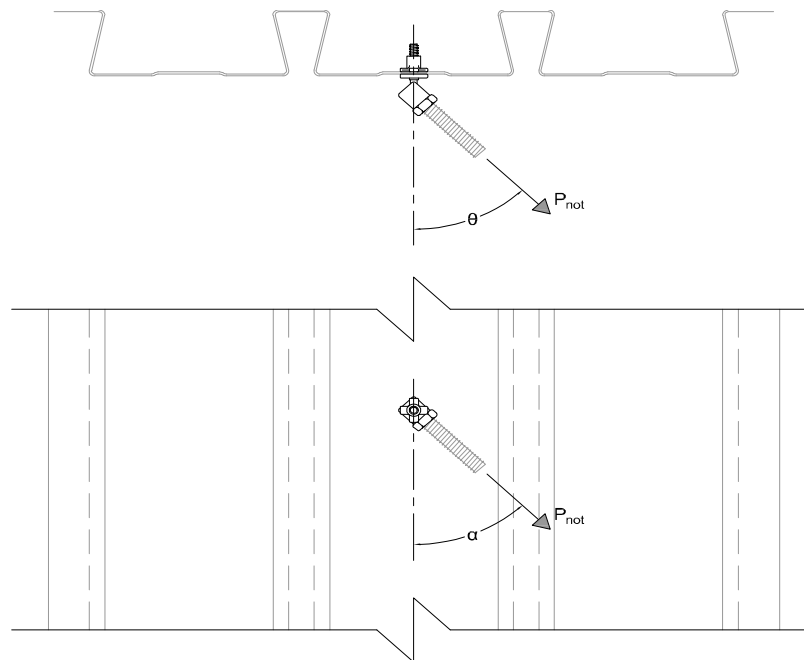

**SAMMYS X-Press Swivel Head<sup>®</sup> Connector**



| WEDGE-NUT HANGING LOAD <sup>1-8</sup> |               |  |                           |                 |
|---------------------------------------|---------------|--|---------------------------|-----------------|
| Deck Type                             | Part Number   | Max. Nominal Fire Sprinkler Pipe Size <sup>9</sup> (in.) | Connection Strength (lbs) |                 |
|                                       |               |  | ASD $P_n/\Omega$          | LRFD $\phi P_n$ |
| 2.0D FormLok                          | 2.0D-WN-3/8NC | 4  | 1392                      | 2297            |
|                                       | 2.0D-WN-1/2NC | 6  |                           |                 |
| 3.5D FormLok                          | 3.5D-WN-3/8NC | 4  | 1996                      | 3294            |
|                                       | 3.5D-WN-1/2NC | 8  |                           |                 |

<sup>1</sup> Minimum compressive strength of normal (145 pcf) or light weight ( $\geq 110$  pcf) concrete,  $f'_c = 2500$  psi.

<sup>2</sup> The concentrated hanging load shall not exceed the bending strength and vertical shear strength of the 2.0D or 3.5D FormLok Composite Steel Deck-Slab.

<sup>3</sup> Hanging load shall not exceed the strength of the threaded rod or bolt provided by others.

<sup>4</sup> The hanging load shall be applied not more than 5 degrees from normal to the plane of deck.

<sup>5</sup> The allowable strength,  $P_n/\Omega$ , shall be equal to or greater than the governing load combination for Allowable Stress Design in the IBC or ASCE/SEI 7.

<sup>6</sup> The factored strength,  $\phi P_n$ , shall be equal to or greater than the governing load combination for Load and Resistance Factor Design in the IBC or ASCE/SEI 7.

<sup>7</sup> Safety and resistance factors are  $\Omega = 2.75$  (ASD) and  $\phi = 0.60$  (LRFD) respectively.

<sup>8</sup> Wedge-nuts shall be installed per manufacturer's instructions.

<sup>9</sup> Maximum fire sprinkler pipe size in accordance with NFPA 13.

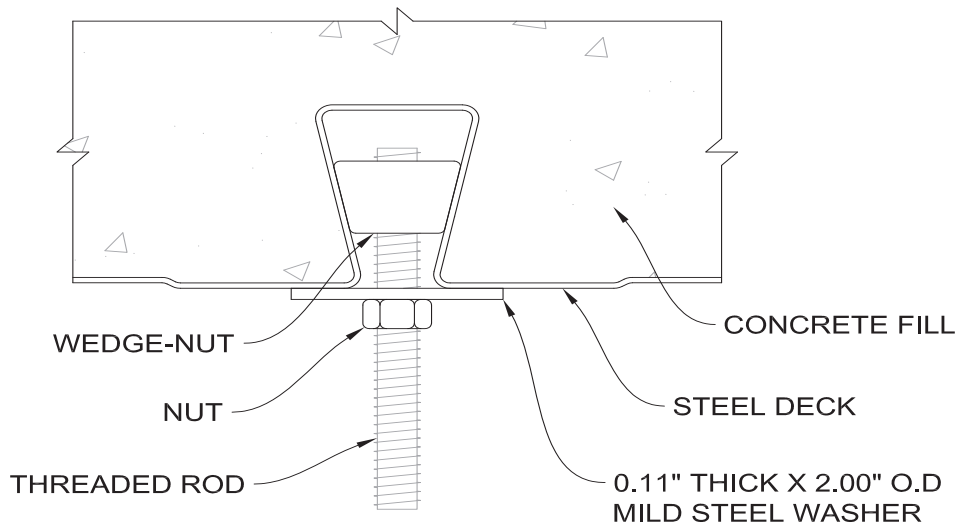

**Wedge-nut**



| NOMINAL STRENGTH OF #12 SCREW INTO PERFORATED MATERIAL (lbs) <sup>1-3</sup> |                                 |                                     |
|---|---------------------------------|-------------------------------------|
| Deck Type   | Shear Strength, P <sub>ns</sub> | Pull-out Strength, P <sub>not</sub> |
| 2.0DA22   | 594                             | 247                                 |
| 2.0DA20   | 715                             | 322                                 |
| 2.0DA19   | 829                             | 392                                 |
| 2.0DA18   | 934                             | 458                                 |
| 2.0DA16   | 1170                            | 604                                 |
| 3.5DA20   | 715                             | 322                                 |
| 3.5DA19   | 829                             | 392                                 |
| 3.5DA18   | 934                             | 458                                 |
| 3.5DA16   | 1170                            | 604                                 |
| 3.5DA14   | 1458                            | 780                                 |

<sup>1</sup> Screw must be installed directly into perforation hole.

<sup>2</sup> Tabulated values are based on perforated material not in contact with the head of the screw. The connecting material in contact with the head of the screw must have a minimum thickness of 16 gage (0.0598") and maximum hole size measuring 1/4" x 5/8".

<sup>3</sup> Safety and resistance factors are  $\Omega = 2.50$  (ASD) and  $\phi = 0.65$  (LRFD) respectively.

| NOMINAL PULL-OVER STRENGTH OF #12 SCREW THRU SOLID MATERIAL WITH SLOTTED HOLE <sup>1-5</sup> |        |                      |
|--|--------|----------------------|
| Gage   | t in.  | P <sub>nov</sub> lbs |
| 16   | 0.0598 | 971                  |

<sup>1</sup> Maximum slotted hole size = 1/4" x 5/8"

<sup>2</sup> Tabulated values are based on a minimum effective pull-over resistance diameter, d'<sub>w</sub> of 0.423".

<sup>3</sup> Tabulated values are based on a minimum tensile strength of steel, F<sub>u</sub> of 65 ksi for solid material with slotted hole.

<sup>4</sup> For eccentrically loaded connections that produce a non-uniform pull-over force on the screw, the nominal pull-over strength shall be taken as 50 percent of P<sub>nov</sub>

<sup>5</sup> Safety and resistance factors are  $\Omega = 2.50$  (ASD) and  $\phi = 0.65$  (LRFD) respectively.

| COMBINED SHEAR AND TENSION EQUATIONS   |  |                 |
|--|--|-----------------|
| The following design equations can be used to check shear and tension interaction for assemblies meeting the requirements of the tables shown above:   |  |                 |
| ASD:   | $\frac{Q}{P_{ns}} + \frac{T}{\min(P_{not}, P_{nov})} \leq \frac{1.0}{\Omega}$  | $\Omega = 2.50$ |
| LRFD:  | $\frac{\bar{Q}}{P_{ns}} + \frac{\bar{T}}{\min(P_{not}, P_{nov})} \leq 1.0\phi$ | $\phi = 0.65$   |
| Where:<br>Q = Required allowable shear strength per connection screw<br>T = Required allowable tension strength per connection screw<br>$\bar{Q}$ = Required shear strength per connection screw<br>$\bar{T}$ = Required tension strength per connection screw |  |                 |



## DEFINITION OF SECTION PROPERTY SYMBOLS

| Symbol     | Definition  | Units               |
|------------|---|---------------------|
| $A_g$      | Gross area of cross-section   | in <sup>2</sup> /ft |
| $A_{gbf}$  | Gross area of bottom flange   | in <sup>2</sup>     |
| $A_n$      | Net area of cross-section   | in <sup>2</sup> /ft |
| $A_{sbf}$  | Cross-sectional area of bottom flange stiffener   | in <sup>2</sup>     |
| $b_{obf}$  | Overall flat width of stiffened bottom flange   | in.                 |
| $b_{pbf}$  | Largest sub-element flat of stiffened bottom flange   | in.                 |
| $c_p$      | Perforation hole center-to-center spacing   | in.                 |
| $c_{sbf}$  | Horizontal distance from edge of bottom flange to centerline of bottom flange stiffener             | in.                 |
| $d_p$      | Perforation hole diameter   | in.                 |
| $E$        | Modulus of elasticity of steel = 29,500   | ksi                 |
| $E_p$      | Width of perforated band in bottom flange   | in.                 |
| $F_u$      | Tensile strength of steel   | ksi                 |
| $F_y$      | Yield strength of steel   | ksi                 |
| $G$        | Shear modulus of steel = 11,300   | ksi                 |
| $h_w$      | Flat dimension of web measured in plane of web  | in.                 |
| $I_{d+}$   | Positive effective moment of inertia for deflection due to uniform loads, $I_{d+}=(2I_{e+}+I_x)/3$  | in <sup>4</sup> /ft |
| $I_{d-}$   | Negative effective moment of inertia for deflection due to uniform loads, $I_{d-}=(2I_{e-}+I_x)/3$  | in <sup>4</sup> /ft |
| $I_{e+}$   | Positive effective moment of inertia  | in <sup>4</sup> /ft |
| $I_{e-}$   | Negative effective moment of inertia  | in <sup>4</sup> /ft |
| $I_{spbf}$ | Moment of inertia of stiffener about centerline of flat portion of bottom flange                    | in <sup>4</sup>     |
| $I_{xg}$   | Moment of inertia of fully effective section  | in <sup>4</sup> /ft |
| $K_{min}$  | Minimum composite deck coefficient  | -                   |
| $M_{n+}$   | Nominal positive flexural strength of deck or panel   | k-ft/ft             |
| $M_{n-}$   | Nominal negative flexural strength of deck or panel   | k-ft/ft             |
| $M_{nxt+}$ | Nominal positive flexural strength with respect to centroidal axis in considering tension yielding  | k-ft/ft             |
| $M_{nxt-}$ | Nominal negative flexural strength with respect to centroidal axis in considering tension yielding  | k-ft/ft             |
| $R$        | Inside bend radius  | in.                 |
| $r$        | Radius of gyration of full unreduced section  | in.                 |
| $S_{e+}$   | Positive effective section modulus  | in <sup>3</sup> /ft |
| $S_{e-}$   | Negative effective section modulus  | in <sup>3</sup> /ft |
| $S_{xb}$   | Section modulus about the X axis for the extreme top fiber of gross section, $S_{xb}=I_{xg}/y_b$    | in <sup>3</sup> /ft |
| $S_{xt}$   | Section modulus about the X axis for the extreme bottom fiber of gross section, $S_{xt}=I_{xg}/y_t$ | in <sup>3</sup> /ft |
| $T_n$      | Nominal tensile axial strength of panel   | k/ft                |
| $t$        | Base steel thickness of panel   | in.                 |
| $V_n$      | Nominal vertical shear strength of panel  | k/ft                |
| $w_{bf}$   | Flat width of bottom flange   | in.                 |
| $w_{dd}$   | Weight of section   | psf                 |
| $w_{tf}$   | Flat width of top flange  | in.                 |
| $y_b$      | Distance from extreme bottom fiber to neutral axis of gross section                                 | in.                 |
| $y_t$      | Distance from extreme top fiber to neutral axis of gross section                                    | in.                 |
| $\theta$   | Angle between plane of web and plane of bearing surface   | deg.                |



Non-Composite Profiles

2.0D

Composite Profiles

2.0D FormLok

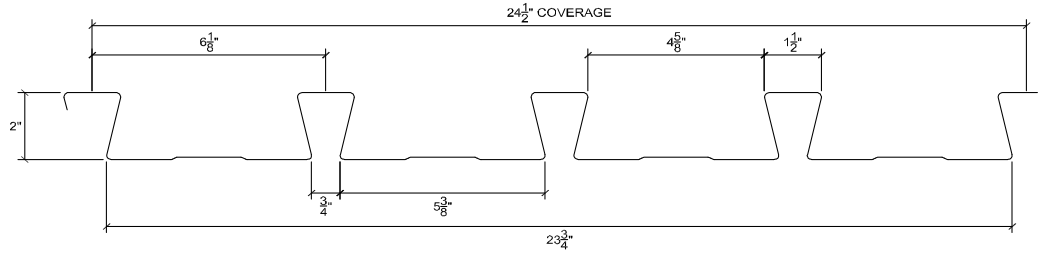

| Gage | t<br>in. | w <sub>dd</sub><br>psf | A <sub>g</sub><br>in <sup>2</sup> /ft | I <sub>xg</sub><br>in <sup>4</sup> /ft | S <sub>xb</sub><br>in <sup>3</sup> /ft | S <sub>xt</sub><br>in <sup>3</sup> /ft | y <sub>b</sub><br>in. | y <sub>t</sub><br>in. | r<br>in. | h <sub>w</sub><br>in. | θ<br>deg. | K <sub>min</sub><br>- |
|------|----------|------------------------|---------------------------------------|--|--|--|-----------------------|-----------------------|----------|-----------------------|-----------|-----------------------|
| 22   | 0.0295   | 2.1                    | 0.626                                 | 0.388                                  | 0.560                                  | 0.290                                  | 0.693                 | 1.337                 | 0.787    | 1.698                 | 79.6      | 0.00                  |
| 20   | 0.0358   | 2.6                    | 0.761                                 | 0.472                                  | 0.677                                  | 0.353                                  | 0.697                 | 1.339                 | 0.788    | 1.691                 | 79.4      | 0.00                  |
| 19   | 0.0418   | 3.0                    | 0.889                                 | 0.551                                  | 0.787                                  | 0.411                                  | 0.700                 | 1.342                 | 0.787    | 1.683                 | 79.2      | 0.00                  |
| 18   | 0.0474   | 3.4                    | 1.009                                 | 0.626                                  | 0.889                                  | 0.466                                  | 0.704                 | 1.343                 | 0.788    | 1.677                 | 78.9      | 0.00                  |
| 16   | 0.0598   | 4.3                    | 1.276                                 | 0.792                                  | 1.114                                  | 0.587                                  | 0.711                 | 1.349                 | 0.788    | 1.662                 | 78.4      | 0.00                  |

| GRADE 40: F <sub>y</sub> = 40 ksi, F <sub>u</sub> = 55 ksi |  |  |  |  |  |  |                            |                            |                              |                              |                        |                        |
|--|--|--|--|--|--|--|----------------------------|----------------------------|------------------------------|------------------------------|------------------------|------------------------|
| Gage   | I <sub>e+</sub><br>in <sup>4</sup> /ft | I <sub>e-</sub><br>in <sup>4</sup> /ft | I <sub>d+</sub><br>in <sup>4</sup> /ft | I <sub>d-</sub><br>in <sup>4</sup> /ft | S <sub>e+</sub><br>in <sup>3</sup> /ft | S <sub>e-</sub><br>in <sup>3</sup> /ft | M <sub>n+</sub><br>k-ft/ft | M <sub>n-</sub><br>k-ft/ft | M <sub>nxt+</sub><br>k-ft/ft | M <sub>nxt-</sub><br>k-ft/ft | V <sub>n</sub><br>k/ft | T <sub>n</sub><br>k/ft |
| 22   | 0.386                                  | 0.345                                  | 0.387                                  | 0.359                                  | 0.272                                  | 0.272                                  | 0.907                      | 0.907                      | 1.867                        | 0.967                        | 4.633                  | 25.04                  |
| 20   | 0.472                                  | 0.435                                  | 0.472                                  | 0.447                                  | 0.343                                  | 0.334                                  | 1.143                      | 1.113                      | 2.257                        | 1.177                        | 5.596                  | 30.44                  |
| 19   | 0.551                                  | 0.523                                  | 0.551                                  | 0.532                                  | 0.406                                  | 0.394                                  | 1.353                      | 1.313                      | 2.623                        | 1.370                        | 6.499                  | 35.56                  |
| 18   | 0.626                                  | 0.605                                  | 0.626                                  | 0.612                                  | 0.463                                  | 0.450                                  | 1.543                      | 1.500                      | 2.963                        | 1.553                        | 7.335                  | 40.36                  |
| 16   | 0.792                                  | 0.791                                  | 0.792                                  | 0.791                                  | 0.587                                  | 0.576                                  | 1.957                      | 1.920                      | 3.713                        | 1.957                        | 9.156                  | 51.04                  |

| R     | w <sub>tf</sub> | w <sub>bf</sub> |
|-------|-----------------|-----------------|
| in.   | in.             | in.             |
| 0.125 | 1.188           | 5.000           |



Acoustic Profiles

2.0DA

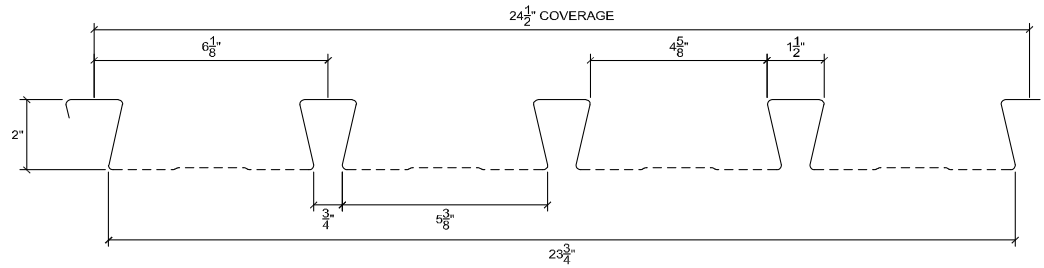

| Gage | t<br>in. | w <sub>dd</sub><br>psf | A <sub>g</sub><br>in <sup>2</sup> /ft | A <sub>n</sub><br>in <sup>2</sup> /ft | I <sub>xg</sub><br>in <sup>4</sup> /ft | S <sub>xb</sub><br>in <sup>3</sup> /ft | S <sub>xt</sub><br>in <sup>3</sup> /ft | y <sub>b</sub><br>in. | y <sub>t</sub><br>in. | r<br>in. | h <sub>w</sub><br>in. | θ<br>deg. |
|------|----------|------------------------|---------------------------------------|---------------------------------------|--|--|--|-----------------------|-----------------------|----------|-----------------------|-----------|
| 22   | 0.0295   | 2.0                    | 0.626                                 | 0.583                                 | 0.341                                  | 0.422                                  | 0.279                                  | 0.808                 | 1.222                 | 0.765    | 1.698                 | 79.6      |
| 20   | 0.0358   | 2.4                    | 0.761                                 | 0.708                                 | 0.415                                  | 0.512                                  | 0.339                                  | 0.811                 | 1.225                 | 0.766    | 1.691                 | 79.4      |
| 19   | 0.0418   | 2.8                    | 0.889                                 | 0.828                                 | 0.485                                  | 0.595                                  | 0.395                                  | 0.815                 | 1.227                 | 0.765    | 1.683                 | 79.2      |
| 18   | 0.0474   | 3.2                    | 1.009                                 | 0.940                                 | 0.551                                  | 0.674                                  | 0.448                                  | 0.818                 | 1.229                 | 0.766    | 1.677                 | 78.9      |
| 16   | 0.0598   | 4.0                    | 1.276                                 | 1.188                                 | 0.697                                  | 0.845                                  | 0.564                                  | 0.825                 | 1.235                 | 0.766    | 1.662                 | 78.4      |

| GRADE 40: F <sub>y</sub> = 40 ksi, F <sub>u</sub> = 55 ksi |  |  |  |  |  |  |                            |                            |                              |                              |                        |                        |
|--|--|--|--|--|--|--|----------------------------|----------------------------|------------------------------|------------------------------|------------------------|------------------------|
| Gage   | I <sub>e+</sub><br>in <sup>4</sup> /ft | I <sub>e-</sub><br>in <sup>4</sup> /ft | I <sub>d+</sub><br>in <sup>4</sup> /ft | I <sub>d-</sub><br>in <sup>4</sup> /ft | S <sub>e+</sub><br>in <sup>3</sup> /ft | S <sub>e-</sub><br>in <sup>3</sup> /ft | M <sub>n+</sub><br>k-ft/ft | M <sub>n-</sub><br>k-ft/ft | M <sub>nxt+</sub><br>k-ft/ft | M <sub>nxt-</sub><br>k-ft/ft | V <sub>n</sub><br>k/ft | T <sub>n</sub><br>k/ft |
| 22   | 0.339                                  | 0.294                                  | 0.340                                  | 0.310                                  | 0.261                                  | 0.258                                  | 0.870                      | 0.860                      | 1.407                        | 0.930                        | 4.633                  | 23.32                  |
| 20   | 0.415                                  | 0.370                                  | 0.415                                  | 0.385                                  | 0.330                                  | 0.317                                  | 1.100                      | 1.057                      | 1.707                        | 1.130                        | 5.596                  | 28.32                  |
| 19   | 0.485                                  | 0.445                                  | 0.485                                  | 0.458                                  | 0.391                                  | 0.374                                  | 1.303                      | 1.247                      | 1.983                        | 1.317                        | 6.499                  | 33.12                  |
| 18   | 0.551                                  | 0.516                                  | 0.551                                  | 0.528                                  | 0.445                                  | 0.427                                  | 1.483                      | 1.423                      | 2.247                        | 1.493                        | 7.335                  | 37.60                  |
| 16   | 0.697                                  | 0.677                                  | 0.697                                  | 0.684                                  | 0.564                                  | 0.546                                  | 1.880                      | 1.820                      | 2.817                        | 1.880                        | 9.156                  | 47.52                  |

| R     | w <sub>tf</sub> | w <sub>br</sub> |
|-------|-----------------|-----------------|
| in.   | in.             | in.             |
| 0.125 | 1.188           | 5.000           |

| d <sub>p</sub> | c <sub>p</sub> | E <sub>p</sub> |
|----------------|----------------|----------------|
| in.            | in.            | in.            |
| 0.154          | 0.375          | 4.654          |





Non-Composite Profiles

3.5D

Composite Profiles

3.5D FormLok

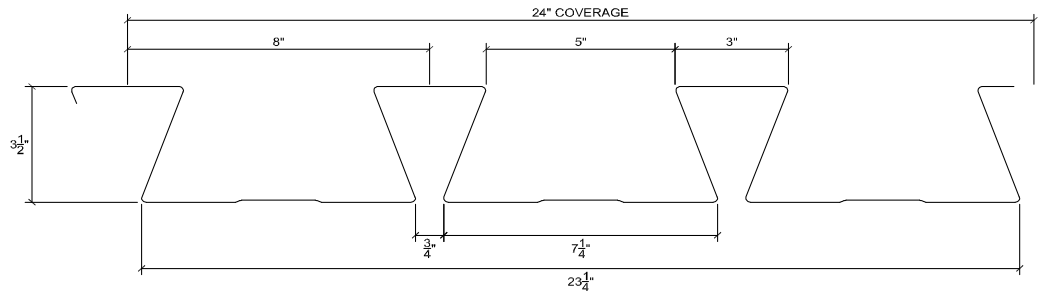

| Gage | t<br>in. | w <sub>dd</sub><br>psf | A <sub>g</sub><br>in <sup>2</sup> /ft | I <sub>xg</sub><br>in <sup>4</sup> /ft | S <sub>xb</sub><br>in <sup>3</sup> /ft | S <sub>xt</sub><br>in <sup>3</sup> /ft | y <sub>b</sub><br>in. | y <sub>t</sub><br>in. | r<br>in. | h <sub>w</sub><br>in. | θ<br>deg. | K <sub>min</sub><br>- |
|------|----------|------------------------|---------------------------------------|--|--|--|-----------------------|-----------------------|----------|-----------------------|-----------|-----------------------|
| 20   | 0.0358   | 3.3                    | 0.955                                 | 1.891                                  | 1.361                                  | 0.881                                  | 1.389                 | 2.147                 | 1.407    | 3.293                 | 71.6      | 0.00                  |
| 19   | 0.0418   | 3.8                    | 1.116                                 | 2.210                                  | 1.588                                  | 1.028                                  | 1.392                 | 2.150                 | 1.407    | 3.286                 | 71.4      | 0.00                  |
| 18   | 0.0474   | 4.3                    | 1.266                                 | 2.508                                  | 1.798                                  | 1.165                                  | 1.395                 | 2.152                 | 1.407    | 3.280                 | 71.3      | 0.00                  |
| 16   | 0.0598   | 5.4                    | 1.600                                 | 3.170                                  | 2.261                                  | 1.469                                  | 1.402                 | 2.158                 | 1.408    | 3.267                 | 71.0      | 0.00                  |

| GRADE 40: F <sub>y</sub> = 40 ksi, F <sub>u</sub> = 55 ksi |  |  |  |  |  |  |                            |                            |                              |                              |                        |                        |
|--|--|--|--|--|--|--|----------------------------|----------------------------|------------------------------|------------------------------|------------------------|------------------------|
| Gage   | I <sub>e+</sub><br>in <sup>4</sup> /ft | I <sub>e-</sub><br>in <sup>4</sup> /ft | I <sub>d+</sub><br>in <sup>4</sup> /ft | I <sub>d-</sub><br>in <sup>4</sup> /ft | S <sub>e+</sub><br>in <sup>3</sup> /ft | S <sub>e-</sub><br>in <sup>3</sup> /ft | M <sub>n+</sub><br>k-ft/ft | M <sub>n-</sub><br>k-ft/ft | M <sub>nxt+</sub><br>k-ft/ft | M <sub>nxt-</sub><br>k-ft/ft | V <sub>n</sub><br>k/ft | T <sub>n</sub><br>k/ft |
| 20   | 1.697                                  | 1.524                                  | 1.762                                  | 1.646                                  | 0.676                                  | 0.781                                  | 2.253                      | 2.603                      | 4.537                        | 2.937                        | 5.496                  | 38.20                  |
| 19   | 2.039                                  | 1.845                                  | 2.096                                  | 1.967                                  | 0.837                                  | 0.934                                  | 2.790                      | 3.113                      | 5.293                        | 3.427                        | 7.484                  | 44.64                  |
| 18   | 2.368                                  | 2.154                                  | 2.415                                  | 2.272                                  | 0.980                                  | 1.070                                  | 3.267                      | 3.567                      | 5.993                        | 3.883                        | 9.619                  | 50.64                  |
| 16   | 3.115                                  | 2.867                                  | 3.133                                  | 2.968                                  | 1.317                                  | 1.377                                  | 4.390                      | 4.590                      | 7.537                        | 4.897                        | 13.300                 | 64.00                  |

| R<br>in. | w <sub>tr</sub><br>in. | w <sub>br</sub><br>in. |
|----------|------------------------|------------------------|
| 0.125    | 2.688                  | 6.850                  |



Acoustic Profiles

3.5DA

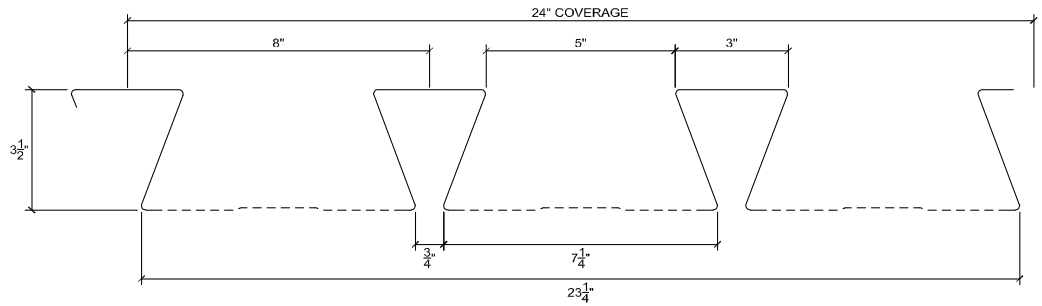

| Gage | t<br>in. | w <sub>dd</sub><br>psf | A <sub>g</sub><br>in <sup>2</sup> /ft | A <sub>n</sub><br>in <sup>2</sup> /ft | I <sub>xg</sub><br>in <sup>4</sup> /ft | S <sub>xb</sub><br>in <sup>3</sup> /ft | S <sub>xt</sub><br>in <sup>3</sup> /ft | y <sub>b</sub><br>in. | y <sub>t</sub><br>in. | r<br>in. | h <sub>w</sub><br>in. | θ<br>deg. |
|------|----------|------------------------|---------------------------------------|---------------------------------------|--|--|--|-----------------------|-----------------------|----------|-----------------------|-----------|
| 20   | 0.0358   | 3.1                    | 0.955                                 | 0.899                                 | 1.639                                  | 1.035                                  | 0.840                                  | 1.584                 | 1.952                 | 1.350    | 3.293                 | 71.6      |
| 19   | 0.0418   | 3.6                    | 1.116                                 | 1.050                                 | 1.915                                  | 1.206                                  | 0.980                                  | 1.588                 | 1.954                 | 1.350    | 3.286                 | 71.4      |
| 18   | 0.0474   | 4.1                    | 1.266                                 | 1.192                                 | 2.174                                  | 1.366                                  | 1.111                                  | 1.591                 | 1.956                 | 1.350    | 3.280                 | 71.3      |
| 16   | 0.0598   | 5.1                    | 1.600                                 | 1.506                                 | 2.748                                  | 1.720                                  | 1.401                                  | 1.598                 | 1.962                 | 1.351    | 3.267                 | 71.0      |

| GRADE 40: F <sub>y</sub> = 40 ksi, F <sub>u</sub> = 55 ksi |  |  |  |  |  |  |                            |                            |                              |                              |                        |                        |
|--|--|--|--|--|--|--|----------------------------|----------------------------|------------------------------|------------------------------|------------------------|------------------------|
| Gage   | I <sub>e+</sub><br>in <sup>4</sup> /ft | I <sub>e-</sub><br>in <sup>4</sup> /ft | I <sub>d+</sub><br>in <sup>4</sup> /ft | I <sub>d-</sub><br>in <sup>4</sup> /ft | S <sub>e+</sub><br>in <sup>3</sup> /ft | S <sub>e-</sub><br>in <sup>3</sup> /ft | M <sub>n+</sub><br>k-ft/ft | M <sub>n-</sub><br>k-ft/ft | M <sub>nxt+</sub><br>k-ft/ft | M <sub>nxt-</sub><br>k-ft/ft | V <sub>n</sub><br>k/ft | T <sub>n</sub><br>k/ft |
| 20   | 1.477                                  | 1.325                                  | 1.531                                  | 1.430                                  | 0.655                                  | 0.657                                  | 2.183                      | 2.190                      | 3.450                        | 2.800                        | 5.496                  | 35.96                  |
| 19   | 1.775                                  | 1.587                                  | 1.822                                  | 1.696                                  | 0.797                                  | 0.794                                  | 2.657                      | 2.647                      | 4.020                        | 3.267                        | 7.484                  | 42.00                  |
| 18   | 2.060                                  | 1.838                                  | 2.098                                  | 1.950                                  | 0.934                                  | 0.928                                  | 3.113                      | 3.093                      | 4.553                        | 3.703                        | 9.619                  | 47.68                  |
| 16   | 2.704                                  | 2.425                                  | 2.719                                  | 2.533                                  | 1.255                                  | 1.241                                  | 4.183                      | 4.137                      | 5.733                        | 4.670                        | 13.300                 | 60.24                  |

| R     | w <sub>tr</sub> | w <sub>br</sub> |
|-------|-----------------|-----------------|
| in.   | in.             | in.             |
| 0.125 | 2.688           | 6.850           |

| d <sub>p</sub> | c <sub>p</sub> | E <sub>p</sub> |
|----------------|----------------|----------------|
| in.            | in.            | in.            |
| 0.156          | 0.375          | 6.344          |



# EVALUATION REPORT

Number:

0423

Originally Issued: 03/10/2017

Revised: 04/02/2024

Valid Through: 03/31/2025

Page 23 of 34

Non-Composite Profiles

2.0DS-30

Composite Profiles

2.0DS-30 FL

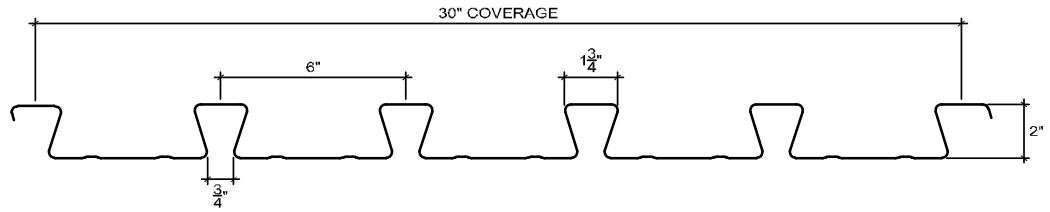

| Gage | t<br>in. | w <sub>dd</sub><br>psf | A <sub>g</sub><br>in <sup>2</sup> /ft | I <sub>xg</sub><br>in <sup>4</sup> /ft | S <sub>xb</sub><br>in <sup>3</sup> /ft | S <sub>xt</sub><br>in <sup>3</sup> /ft | y <sub>b</sub><br>in. | y <sub>t</sub><br>in. | r<br>in. | h <sub>w</sub><br>in. | θ<br>deg. | K <sub>min</sub><br>- |
|------|----------|------------------------|---------------------------------------|--|--|--|-----------------------|-----------------------|----------|-----------------------|-----------|-----------------------|
| 22   | 0.0299   | 2.2                    | 0.661                                 | 0.433                                  | 0.584                                  | 0.336                                  | 0.742                 | 1.288                 | 0.809    | 1.542                 | 75.6      | 0.00                  |
| 21   | 0.0329   | 2.5                    | 0.728                                 | 0.477                                  | 0.641                                  | 0.370                                  | 0.743                 | 1.289                 | 0.809    | 1.538                 | 75.5      | 0.00                  |
| 20   | 0.0359   | 2.7                    | 0.795                                 | 0.520                                  | 0.698                                  | 0.403                                  | 0.745                 | 1.291                 | 0.809    | 1.534                 | 75.3      | 0.00                  |
| 19   | 0.0418   | 3.2                    | 0.926                                 | 0.607                                  | 0.811                                  | 0.469                                  | 0.748                 | 1.293                 | 0.809    | 1.526                 | 75.1      | 0.00                  |
| 18   | 0.0478   | 3.6                    | 1.061                                 | 0.695                                  | 0.924                                  | 0.536                                  | 0.752                 | 1.296                 | 0.809    | 1.518                 | 74.8      | 0.00                  |
| 17   | 0.0538   | 4.1                    | 1.195                                 | 0.783                                  | 1.037                                  | 0.603                                  | 0.755                 | 1.299                 | 0.809    | 1.510                 | 74.5      | 0.00                  |
| 16   | 0.0598   | 4.5                    | 1.330                                 | 0.872                                  | 1.149                                  | 0.670                                  | 0.759                 | 1.301                 | 0.810    | 1.502                 | 74.2      | 0.00                  |

| GRADE 50: F <sub>y</sub> = 50 ksi, F <sub>u</sub> = 65 ksi |  |  |  |  |  |  |                            |                            |                              |                              |                        |                        |
|--|--|--|--|--|--|--|----------------------------|----------------------------|------------------------------|------------------------------|------------------------|------------------------|
| Gage   | I <sub>e+</sub><br>in <sup>4</sup> /ft | I <sub>e-</sub><br>in <sup>4</sup> /ft | I <sub>d+</sub><br>in <sup>4</sup> /ft | I <sub>d-</sub><br>in <sup>4</sup> /ft | S <sub>e+</sub><br>in <sup>3</sup> /ft | S <sub>e-</sub><br>in <sup>3</sup> /ft | M <sub>n+</sub><br>k-ft/ft | M <sub>n-</sub><br>k-ft/ft | M <sub>nxt+</sub><br>k-ft/ft | M <sub>nxt-</sub><br>k-ft/ft | V <sub>n</sub><br>k/ft | T <sub>n</sub><br>k/ft |
| 22   | 0.429                                  | 0.357                                  | 0.430                                  | 0.382                                  | 0.301                                  | 0.306                                  | 1.255                      | 1.273                      | 2.431                        | 1.400                        | 5.335                  | 33.06                  |
| 21   | 0.475                                  | 0.403                                  | 0.476                                  | 0.427                                  | 0.339                                  | 0.339                                  | 1.413                      | 1.413                      | 2.671                        | 1.540                        | 5.852                  | 36.40                  |
| 20   | 0.520                                  | 0.450                                  | 0.520                                  | 0.473                                  | 0.378                                  | 0.373                                  | 1.574                      | 1.553                      | 2.910                        | 1.680                        | 6.365                  | 39.74                  |
| 19   | 0.607                                  | 0.545                                  | 0.607                                  | 0.565                                  | 0.454                                  | 0.440                                  | 1.893                      | 1.832                      | 3.378                        | 1.955                        | 7.364                  | 46.32                  |
| 18   | 0.695                                  | 0.644                                  | 0.695                                  | 0.661                                  | 0.527                                  | 0.509                                  | 2.197                      | 2.119                      | 3.850                        | 2.234                        | 8.367                  | 53.03                  |
| 17   | 0.783                                  | 0.746                                  | 0.783                                  | 0.758                                  | 0.598                                  | 0.578                                  | 2.493                      | 2.409                      | 4.320                        | 2.512                        | 9.354                  | 59.75                  |
| 16   | 0.872                                  | 0.849                                  | 0.872                                  | 0.856                                  | 0.667                                  | 0.648                                  | 2.779                      | 2.700                      | 4.787                        | 2.791                        | 10.328                 | 66.49                  |

| Gage | A <sub>gbf</sub><br>in <sup>2</sup> | A <sub>sbf</sub><br>in <sup>2</sup> | I <sub>spbf</sub><br>in <sup>4</sup> |
|------|-------------------------------------|-------------------------------------|--------------------------------------|
| 22   | 0.142                               | 0.019                               | 3.99E-05                             |
| 21   | 0.156                               | 0.021                               | 4.43E-05                             |
| 20   | 0.170                               | 0.023                               | 4.88E-05                             |
| 19   | 0.198                               | 0.027                               | 5.80E-05                             |
| 18   | 0.227                               | 0.031                               | 6.78E-05                             |
| 17   | 0.255                               | 0.035                               | 7.83E-05                             |
| 16   | 0.284                               | 0.039                               | 8.95E-05                             |

| R     | w <sub>tf</sub> | w <sub>bf</sub> |
|-------|-----------------|-----------------|
| in.   | in.             | in.             |
| 0.188 | 1.275           | 4.704           |

| b <sub>obf</sub> | b <sub>pbf</sub> | c <sub>sbf</sub> |
|------------------|------------------|------------------|
| in.              | in.              | in.              |
| 4.704            | 1.500            | 1.290            |



# EVALUATION REPORT

Number:

0423

Originally Issued: 03/10/2017

Revised: 04/02/2024

Valid Through: 03/31/2025

Page 24 of 34

Acoustic Profiles

2.0DS-30 AC

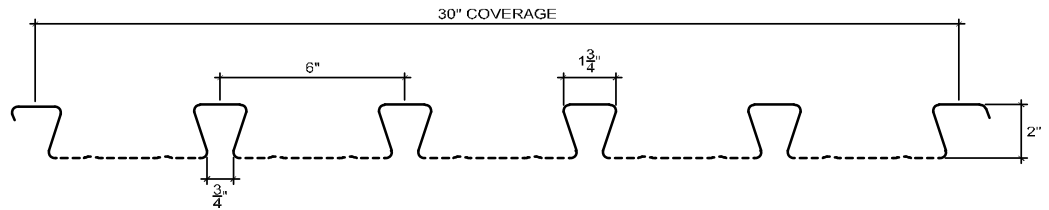

| Gage | t<br>in. | w <sub>dd</sub><br>psf | A <sub>g</sub><br>in <sup>2</sup> /ft | A <sub>n</sub><br>in <sup>2</sup> /ft | I <sub>xg</sub><br>in <sup>4</sup> /ft | S <sub>xb</sub><br>in <sup>3</sup> /ft | S <sub>xt</sub><br>in <sup>3</sup> /ft | y <sub>b</sub><br>in. | y <sub>t</sub><br>in. | r<br>in. | h <sub>w</sub><br>in. | θ<br>deg. |
|------|----------|------------------------|---------------------------------------|---------------------------------------|--|--|--|-----------------------|-----------------------|----------|-----------------------|-----------|
| 22   | 0.0299   | 2.1                    | 0.661                                 | 0.616                                 | 0.405                                  | 0.510                                  | 0.327                                  | 0.794                 | 1.236                 | 0.810    | 1.542                 | 75.6      |
| 21   | 0.0329   | 2.3                    | 0.728                                 | 0.679                                 | 0.446                                  | 0.560                                  | 0.360                                  | 0.795                 | 1.238                 | 0.810    | 1.538                 | 75.5      |
| 20   | 0.0359   | 2.5                    | 0.795                                 | 0.741                                 | 0.487                                  | 0.610                                  | 0.393                                  | 0.797                 | 1.239                 | 0.810    | 1.534                 | 75.3      |
| 19   | 0.0418   | 2.9                    | 0.926                                 | 0.864                                 | 0.567                                  | 0.709                                  | 0.457                                  | 0.800                 | 1.241                 | 0.810    | 1.526                 | 75.1      |
| 18   | 0.0478   | 3.4                    | 1.061                                 | 0.989                                 | 0.650                                  | 0.808                                  | 0.522                                  | 0.804                 | 1.244                 | 0.810    | 1.518                 | 74.8      |
| 17   | 0.0538   | 3.8                    | 1.195                                 | 1.115                                 | 0.732                                  | 0.907                                  | 0.587                                  | 0.807                 | 1.247                 | 0.810    | 1.510                 | 74.5      |
| 16   | 0.0598   | 4.3                    | 1.330                                 | 1.250                                 | 0.822                                  | 1.022                                  | 0.655                                  | 0.805                 | 1.255                 | 0.811    | 1.502                 | 74.2      |

| GRADE 50: F <sub>y</sub> = 50 ksi, F <sub>u</sub> = 65 ksi |  |  |  |  |  |  |                            |                            |                              |                              |                        |                        |
|--|--|--|--|--|--|--|----------------------------|----------------------------|------------------------------|------------------------------|------------------------|------------------------|
| Gage   | I <sub>e+</sub><br>in <sup>4</sup> /ft | I <sub>e-</sub><br>in <sup>4</sup> /ft | I <sub>d+</sub><br>in <sup>4</sup> /ft | I <sub>d-</sub><br>in <sup>4</sup> /ft | S <sub>e+</sub><br>in <sup>3</sup> /ft | S <sub>e-</sub><br>in <sup>3</sup> /ft | M <sub>n+</sub><br>k-ft/ft | M <sub>n-</sub><br>k-ft/ft | M <sub>nxt+</sub><br>k-ft/ft | M <sub>nxt-</sub><br>k-ft/ft | V <sub>n</sub><br>k/ft | T <sub>n</sub><br>k/ft |
| 22   | 0.352                                  | 0.295                                  | 0.370                                  | 0.331                                  | 0.281                                  | 0.252                                  | 1.170                      | 1.050                      | 2.124                        | 1.364                        | 5.335                  | 30.82                  |
| 21   | 0.390                                  | 0.338                                  | 0.408                                  | 0.374                                  | 0.316                                  | 0.294                                  | 1.318                      | 1.223                      | 2.334                        | 1.500                        | 5.852                  | 33.94                  |
| 20   | 0.426                                  | 0.383                                  | 0.446                                  | 0.417                                  | 0.352                                  | 0.337                                  | 1.465                      | 1.405                      | 2.544                        | 1.636                        | 6.365                  | 37.05                  |
| 19   | 0.497                                  | 0.476                                  | 0.520                                  | 0.506                                  | 0.415                                  | 0.412                                  | 1.728                      | 1.717                      | 2.953                        | 1.904                        | 7.364                  | 43.19                  |
| 18   | 0.569                                  | 0.575                                  | 0.596                                  | 0.600                                  | 0.481                                  | 0.482                                  | 2.006                      | 2.010                      | 3.368                        | 2.175                        | 8.367                  | 49.46                  |
| 17   | 0.641                                  | 0.676                                  | 0.671                                  | 0.695                                  | 0.543                                  | 0.553                                  | 2.263                      | 2.304                      | 3.780                        | 2.447                        | 9.354                  | 55.73                  |
| 16   | 0.737                                  | 0.778                                  | 0.765                                  | 0.793                                  | 0.617                                  | 0.624                                  | 2.572                      | 2.600                      | 4.257                        | 2.728                        | 10.328                 | 62.50                  |

| Gage | A <sub>gbf</sub><br>in <sup>2</sup> | A <sub>sbf</sub><br>in <sup>2</sup> | I <sub>sbbf</sub><br>in <sup>4</sup> |
|------|-------------------------------------|-------------------------------------|--------------------------------------|
| 22   | 0.142                               | 0.019                               | 3.99E-05                             |
| 21   | 0.156                               | 0.021                               | 4.43E-05                             |
| 20   | 0.170                               | 0.023                               | 4.88E-05                             |
| 19   | 0.198                               | 0.027                               | 5.80E-05                             |
| 18   | 0.227                               | 0.031                               | 6.78E-05                             |
| 17   | 0.255                               | 0.035                               | 7.83E-05                             |
| 16   | 0.284                               | 0.039                               | 8.95E-05                             |

| R     | w <sub>tf</sub> | w <sub>bf</sub> |
|-------|-----------------|-----------------|
| in.   | in.             | in.             |
| 0.188 | 1.275           | 4.704           |

| b <sub>obf</sub> | b <sub>pbf</sub> | c <sub>sbf</sub> |
|------------------|------------------|------------------|
| in.              | in.              | in.              |
| 4.704            | 1.500            | 1.290            |

| d <sub>p</sub> | c <sub>p</sub> |
|----------------|----------------|
| in.            | in.            |
| 0.156          | 0.375          |



# EVALUATION REPORT

Number:

0423

Originally Issued: 03/10/2017

Revised: 04/02/2024

Valid Through: 03/31/2025

Page 25 of 34

Acoustic Profiles

2.0DS-30 ACW

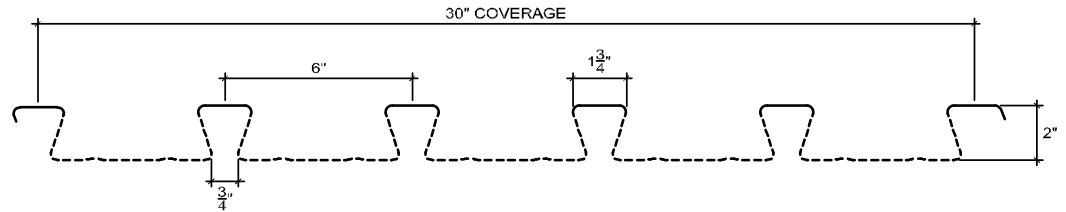

| Gage | t<br>in. | w <sub>dd</sub><br>psf | A <sub>g</sub><br>in <sup>2</sup> /ft | A <sub>n</sub><br>in <sup>2</sup> /ft | I <sub>xg</sub><br>in <sup>4</sup> /ft | S <sub>xb</sub><br>in <sup>3</sup> /ft | S <sub>xt</sub><br>in <sup>3</sup> /ft | y <sub>b</sub><br>in. | y <sub>t</sub><br>in. | r<br>in. | h <sub>w</sub><br>in. | θ<br>deg. |
|------|----------|------------------------|---------------------------------------|---------------------------------------|--|--|--|-----------------------|-----------------------|----------|-----------------------|-----------|
| 22   | 0.0299   | 2.0                    | 0.661                                 | 0.580                                 | 0.395                                  | 0.499                                  | 0.319                                  | 0.791                 | 1.239                 | 0.825    | 1.542                 | 75.6      |
| 21   | 0.0329   | 2.1                    | 0.728                                 | 0.628                                 | 0.426                                  | 0.541                                  | 0.343                                  | 0.789                 | 1.244                 | 0.824    | 1.538                 | 75.5      |
| 20   | 0.0359   | 2.4                    | 0.795                                 | 0.698                                 | 0.475                                  | 0.598                                  | 0.382                                  | 0.794                 | 1.242                 | 0.825    | 1.534                 | 75.3      |
| 19   | 0.0418   | 2.8                    | 0.926                                 | 0.814                                 | 0.554                                  | 0.694                                  | 0.445                                  | 0.798                 | 1.244                 | 0.825    | 1.526                 | 75.1      |
| 18   | 0.0478   | 3.2                    | 1.061                                 | 0.932                                 | 0.634                                  | 0.791                                  | 0.509                                  | 0.801                 | 1.246                 | 0.825    | 1.518                 | 74.8      |
| 17   | 0.0538   | 3.6                    | 1.195                                 | 1.050                                 | 0.715                                  | 0.888                                  | 0.572                                  | 0.805                 | 1.249                 | 0.825    | 1.510                 | 74.5      |
| 16   | 0.0598   | 4.0                    | 1.330                                 | 1.169                                 | 0.796                                  | 0.984                                  | 0.636                                  | 0.809                 | 1.251                 | 0.825    | 1.502                 | 74.2      |

| GRADE 50: F <sub>y</sub> = 50 ksi, F <sub>u</sub> = 65 ksi |  |  |  |  |  |  |                            |                            |                              |                              |                        |                        |
|--|--|--|--|--|--|--|----------------------------|----------------------------|------------------------------|------------------------------|------------------------|------------------------|
| Gage   | I <sub>e+</sub><br>in <sup>4</sup> /ft | I <sub>e-</sub><br>in <sup>4</sup> /ft | I <sub>d+</sub><br>in <sup>4</sup> /ft | I <sub>d-</sub><br>in <sup>4</sup> /ft | S <sub>e+</sub><br>in <sup>3</sup> /ft | S <sub>e-</sub><br>in <sup>3</sup> /ft | M <sub>n+</sub><br>k-ft/ft | M <sub>n-</sub><br>k-ft/ft | M <sub>nxt+</sub><br>k-ft/ft | M <sub>nxt-</sub><br>k-ft/ft | V <sub>n</sub><br>k/ft | T <sub>n</sub><br>k/ft |
| 22   | 0.330                                  | 0.266                                  | 0.352                                  | 0.309                                  | 0.268                                  | 0.213                                  | 1.116                      | 0.889                      | 2.080                        | 1.328                        | 3.508                  | 29.02                  |
| 21   | 0.348                                  | 0.296                                  | 0.374                                  | 0.340                                  | 0.286                                  | 0.241                                  | 1.193                      | 1.004                      | 2.253                        | 1.428                        | 3.848                  | 31.41                  |
| 20   | 0.398                                  | 0.358                                  | 0.423                                  | 0.397                                  | 0.331                                  | 0.301                                  | 1.380                      | 1.253                      | 2.491                        | 1.594                        | 4.185                  | 34.90                  |
| 19   | 0.464                                  | 0.446                                  | 0.494                                  | 0.482                                  | 0.391                                  | 0.385                                  | 1.630                      | 1.602                      | 2.891                        | 1.854                        | 4.842                  | 40.68                  |
| 18   | 0.531                                  | 0.543                                  | 0.565                                  | 0.573                                  | 0.452                                  | 0.453                                  | 1.885                      | 1.889                      | 3.297                        | 2.120                        | 5.501                  | 46.59                  |
| 17   | 0.598                                  | 0.642                                  | 0.637                                  | 0.666                                  | 0.511                                  | 0.522                                  | 2.128                      | 2.175                      | 3.699                        | 2.385                        | 6.151                  | 52.50                  |
| 16   | 0.666                                  | 0.741                                  | 0.709                                  | 0.759                                  | 0.568                                  | 0.591                                  | 2.369                      | 2.461                      | 4.100                        | 2.649                        | 6.791                  | 58.44                  |

| Gage | A <sub>gbf</sub><br>in <sup>2</sup> | A <sub>sbf</sub><br>in <sup>2</sup> | I <sub>spbf</sub><br>in <sup>4</sup> |
|------|-------------------------------------|-------------------------------------|--------------------------------------|
| 22   | 0.142                               | 0.019                               | 3.99E-05                             |
| 21   | 0.156                               | 0.021                               | 4.43E-05                             |
| 20   | 0.170                               | 0.023                               | 4.88E-05                             |
| 19   | 0.198                               | 0.027                               | 5.80E-05                             |
| 18   | 0.227                               | 0.031                               | 6.78E-05                             |
| 17   | 0.255                               | 0.035                               | 7.83E-05                             |
| 16   | 0.284                               | 0.039                               | 8.95E-05                             |

| R     | w <sub>tf</sub> | w <sub>bf</sub> |
|-------|-----------------|-----------------|
| in.   | in.             | in.             |
| 0.188 | 1.275           | 4.704           |

| b <sub>obf</sub> | b <sub>pbf</sub> | c <sub>sbf</sub> |
|------------------|------------------|------------------|
| in.              | in.              | in.              |
| 4.704            | 1.500            | 1.290            |

| d <sub>p</sub> | c <sub>p</sub> |
|----------------|----------------|
| in.            | in.            |
| 0.156          | 0.375          |



# EVALUATION REPORT

Number:

0423

Originally Issued: 03/10/2017

Revised: 04/02/2024

Valid Through: 03/31/2025

Page 26 of 34

Non-Composite Profiles

**2.0DF-30**

Composite Profiles

**2.0DF-30 FL**

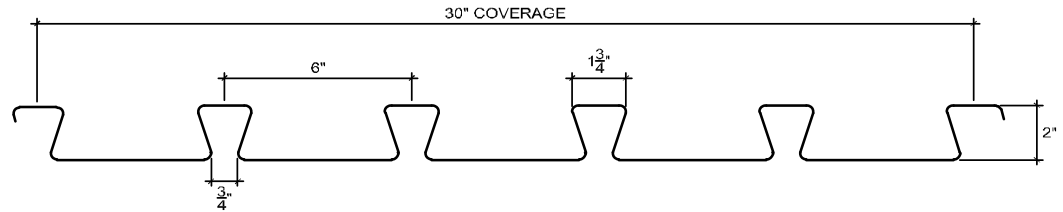

| Gage | t<br>in. | w <sub>dd</sub><br>psf | A <sub>g</sub><br>in <sup>2</sup> /ft | I <sub>xg</sub><br>in <sup>4</sup> /ft | S <sub>xb</sub><br>in <sup>3</sup> /ft | S <sub>xt</sub><br>in <sup>3</sup> /ft | y <sub>b</sub><br>in. | y <sub>t</sub><br>in. | r<br>in. | h <sub>w</sub><br>in. | θ<br>deg. | K <sub>min</sub><br>- |
|------|----------|------------------------|---------------------------------------|--|--|--|-----------------------|-----------------------|----------|-----------------------|-----------|-----------------------|
| 22   | 0.0299   | 2.2                    | 0.659                                 | 0.436                                  | 0.589                                  | 0.338                                  | 0.740                 | 1.290                 | 0.813    | 1.542                 | 75.6      | 0.00                  |
| 21   | 0.0329   | 2.5                    | 0.725                                 | 0.480                                  | 0.647                                  | 0.372                                  | 0.742                 | 1.291                 | 0.813    | 1.538                 | 75.5      | 0.00                  |
| 20   | 0.0359   | 2.7                    | 0.792                                 | 0.524                                  | 0.705                                  | 0.405                                  | 0.743                 | 1.293                 | 0.813    | 1.534                 | 75.3      | 0.00                  |
| 19   | 0.0418   | 3.1                    | 0.923                                 | 0.611                                  | 0.818                                  | 0.472                                  | 0.747                 | 1.295                 | 0.813    | 1.526                 | 75.1      | 0.00                  |
| 18   | 0.0478   | 3.6                    | 1.057                                 | 0.699                                  | 0.932                                  | 0.539                                  | 0.750                 | 1.298                 | 0.814    | 1.518                 | 74.8      | 0.00                  |
| 17   | 0.0538   | 4.1                    | 1.191                                 | 0.788                                  | 1.046                                  | 0.606                                  | 0.754                 | 1.300                 | 0.814    | 1.510                 | 74.5      | 0.00                  |
| 16   | 0.0598   | 4.5                    | 1.325                                 | 0.877                                  | 1.159                                  | 0.673                                  | 0.757                 | 1.303                 | 0.814    | 1.502                 | 74.2      | 0.00                  |

| GRADE 50: F <sub>y</sub> = 50 ksi, F <sub>u</sub> = 65 ksi |  |  |  |  |  |  |                            |                            |                              |                              |                        |                        |
|--|--|--|--|--|--|--|----------------------------|----------------------------|------------------------------|------------------------------|------------------------|------------------------|
| Gage   | I <sub>e+</sub><br>in <sup>4</sup> /ft | I <sub>e-</sub><br>in <sup>4</sup> /ft | I <sub>d+</sub><br>in <sup>4</sup> /ft | I <sub>d-</sub><br>in <sup>4</sup> /ft | S <sub>e+</sub><br>in <sup>3</sup> /ft | S <sub>e-</sub><br>in <sup>3</sup> /ft | M <sub>n+</sub><br>k-ft/ft | M <sub>n-</sub><br>k-ft/ft | M <sub>nxt+</sub><br>k-ft/ft | M <sub>nxt-</sub><br>k-ft/ft | V <sub>n</sub><br>k/ft | T <sub>n</sub><br>k/ft |
| 22   | 0.432                                  | 0.347                                  | 0.433                                  | 0.377                                  | 0.303                                  | 0.264                                  | 1.262                      | 1.100                      | 2.454                        | 1.407                        | 5.335                  | 32.94                  |
| 21   | 0.478                                  | 0.393                                  | 0.479                                  | 0.422                                  | 0.341                                  | 0.303                                  | 1.421                      | 1.263                      | 2.695                        | 1.548                        | 5.852                  | 36.26                  |
| 20   | 0.523                                  | 0.441                                  | 0.524                                  | 0.468                                  | 0.380                                  | 0.344                                  | 1.582                      | 1.434                      | 2.936                        | 1.689                        | 6.365                  | 39.59                  |
| 19   | 0.611                                  | 0.537                                  | 0.611                                  | 0.562                                  | 0.457                                  | 0.422                                  | 1.902                      | 1.758                      | 3.408                        | 1.965                        | 7.364                  | 46.15                  |
| 18   | 0.699                                  | 0.640                                  | 0.699                                  | 0.660                                  | 0.530                                  | 0.491                                  | 2.208                      | 2.046                      | 3.884                        | 2.245                        | 8.367                  | 52.83                  |
| 17   | 0.788                                  | 0.743                                  | 0.788                                  | 0.758                                  | 0.601                                  | 0.561                                  | 2.506                      | 2.337                      | 4.358                        | 2.525                        | 9.354                  | 59.53                  |
| 16   | 0.877                                  | 0.846                                  | 0.877                                  | 0.857                                  | 0.670                                  | 0.632                                  | 2.793                      | 2.632                      | 4.829                        | 2.805                        | 10.328                 | 66.24                  |

| R<br>in. | w <sub>tf</sub><br>in. | w <sub>bf</sub><br>in. |
|----------|------------------------|------------------------|
| 0.188    | 1.275                  | 4.704                  |





# EVALUATION REPORT

Number:

0423

Originally Issued: 03/10/2017

Revised: 04/02/2024

Valid Through: 03/31/2025

Page 27 of 34

Acoustic Profiles

2.0DF-30 AC

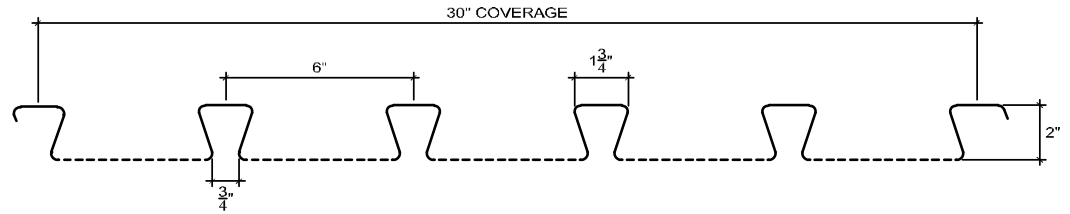

| Gage | t<br>in. | w <sub>dd</sub><br>psf | A <sub>g</sub><br>in <sup>2</sup> /ft | A <sub>n</sub><br>in <sup>2</sup> /ft | I <sub>xg</sub><br>in <sup>4</sup> /ft | S <sub>xb</sub><br>in <sup>3</sup> /ft | S <sub>xt</sub><br>in <sup>3</sup> /ft | y <sub>b</sub><br>in. | y <sub>t</sub><br>in. | r<br>in. | h <sub>w</sub><br>in. | θ<br>deg. |
|------|----------|------------------------|---------------------------------------|---------------------------------------|--|--|--|-----------------------|-----------------------|----------|-----------------------|-----------|
| 22   | 0.0299   | 2.1                    | 0.659                                 | 0.614                                 | 0.407                                  | 0.514                                  | 0.329                                  | 0.792                 | 1.238                 | 0.814    | 1.542                 | 75.6      |
| 21   | 0.0329   | 2.3                    | 0.725                                 | 0.676                                 | 0.448                                  | 0.565                                  | 0.362                                  | 0.794                 | 1.239                 | 0.814    | 1.538                 | 75.5      |
| 20   | 0.0359   | 2.5                    | 0.792                                 | 0.739                                 | 0.490                                  | 0.615                                  | 0.395                                  | 0.796                 | 1.240                 | 0.814    | 1.534                 | 75.3      |
| 19   | 0.0418   | 2.9                    | 0.923                                 | 0.861                                 | 0.571                                  | 0.714                                  | 0.459                                  | 0.799                 | 1.243                 | 0.814    | 1.526                 | 75.1      |
| 18   | 0.0478   | 3.4                    | 1.057                                 | 0.986                                 | 0.654                                  | 0.815                                  | 0.525                                  | 0.802                 | 1.246                 | 0.814    | 1.518                 | 74.8      |
| 17   | 0.0538   | 3.8                    | 1.191                                 | 1.111                                 | 0.737                                  | 0.914                                  | 0.590                                  | 0.806                 | 1.248                 | 0.814    | 1.510                 | 74.5      |
| 16   | 0.0598   | 4.2                    | 1.325                                 | 1.236                                 | 0.820                                  | 1.013                                  | 0.655                                  | 0.809                 | 1.251                 | 0.814    | 1.502                 | 74.2      |

| GRADE 50: F <sub>y</sub> = 50 ksi, F <sub>u</sub> = 65 ksi |  |  |  |  |  |  |                            |                            |                              |                              |                        |                        |
|--|--|--|--|--|--|--|----------------------------|----------------------------|------------------------------|------------------------------|------------------------|------------------------|
| Gage   | I <sub>e+</sub><br>in <sup>4</sup> /ft | I <sub>e-</sub><br>in <sup>4</sup> /ft | I <sub>d+</sub><br>in <sup>4</sup> /ft | I <sub>d-</sub><br>in <sup>4</sup> /ft | S <sub>e+</sub><br>in <sup>3</sup> /ft | S <sub>e-</sub><br>in <sup>3</sup> /ft | M <sub>n+</sub><br>k-ft/ft | M <sub>n-</sub><br>k-ft/ft | M <sub>nxt+</sub><br>k-ft/ft | M <sub>nxt-</sub><br>k-ft/ft | V <sub>n</sub><br>k/ft | T <sub>n</sub><br>k/ft |
| 22   | 0.354                                  | 0.317                                  | 0.372                                  | 0.347                                  | 0.282                                  | 0.235                                  | 1.175                      | 0.979                      | 2.142                        | 1.371                        | 5.335                  | 30.72                  |
| 21   | 0.392                                  | 0.359                                  | 0.411                                  | 0.389                                  | 0.318                                  | 0.269                                  | 1.324                      | 1.122                      | 2.353                        | 1.508                        | 5.852                  | 33.82                  |
| 20   | 0.428                                  | 0.401                                  | 0.449                                  | 0.431                                  | 0.353                                  | 0.306                                  | 1.471                      | 1.275                      | 2.564                        | 1.644                        | 6.365                  | 36.93                  |
| 19   | 0.499                                  | 0.486                                  | 0.523                                  | 0.514                                  | 0.417                                  | 0.384                                  | 1.736                      | 1.601                      | 2.977                        | 1.913                        | 7.364                  | 43.05                  |
| 18   | 0.572                                  | 0.573                                  | 0.599                                  | 0.600                                  | 0.483                                  | 0.469                                  | 2.014                      | 1.953                      | 3.394                        | 2.186                        | 8.367                  | 49.29                  |
| 17   | 0.644                                  | 0.663                                  | 0.675                                  | 0.688                                  | 0.546                                  | 0.540                                  | 2.273                      | 2.252                      | 3.809                        | 2.459                        | 9.354                  | 55.54                  |
| 16   | 0.717                                  | 0.751                                  | 0.752                                  | 0.774                                  | 0.608                                  | 0.614                                  | 2.534                      | 2.559                      | 4.222                        | 2.731                        | 10.328                 | 61.81                  |

| R     | w <sub>tf</sub> | w <sub>bf</sub> |
|-------|-----------------|-----------------|
| in.   | in.             | in.             |
| 0.188 | 1.275           | 4.704           |

| d <sub>p</sub> | c <sub>p</sub> |
|----------------|----------------|
| in.            | in.            |
| 0.156          | 0.375          |



# EVALUATION REPORT

Number:

0423

Originally Issued: 03/10/2017

Revised: 04/02/2024

Valid Through: 03/31/2025

Page 28 of 34

Acoustic Profiles

2.0DF-30 ACW

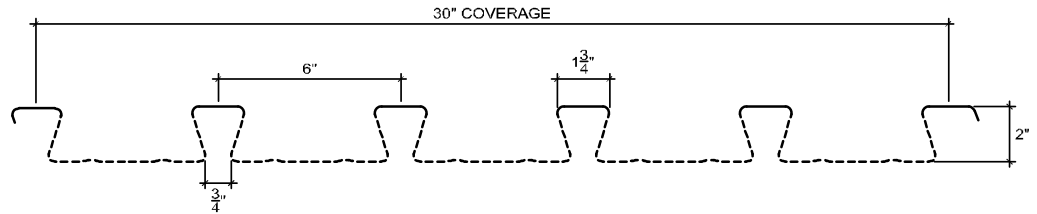

| Gage | t<br>in. | w <sub>dd</sub><br>psf | A <sub>g</sub><br>in <sup>2</sup> /ft | A <sub>n</sub><br>in <sup>2</sup> /ft | I <sub>xg</sub><br>in <sup>4</sup> /ft | S <sub>xb</sub><br>in <sup>3</sup> /ft | S <sub>xt</sub><br>in <sup>3</sup> /ft | y <sub>b</sub><br>in. | y <sub>t</sub><br>in. | r<br>in. | h <sub>w</sub><br>in. | θ<br>deg. |
|------|----------|------------------------|---------------------------------------|---------------------------------------|--|--|--|-----------------------|-----------------------|----------|-----------------------|-----------|
| 22   | 0.0299   | 2.0                    | 0.659                                 | 0.578                                 | 0.397                                  | 0.503                                  | 0.320                                  | 0.789                 | 1.241                 | 0.829    | 1.542                 | 75.6      |
| 21   | 0.0329   | 2.2                    | 0.725                                 | 0.637                                 | 0.438                                  | 0.553                                  | 0.352                                  | 0.791                 | 1.242                 | 0.829    | 1.538                 | 75.5      |
| 20   | 0.0359   | 2.4                    | 0.792                                 | 0.695                                 | 0.478                                  | 0.603                                  | 0.384                                  | 0.793                 | 1.243                 | 0.829    | 1.534                 | 75.3      |
| 19   | 0.0418   | 2.8                    | 0.923                                 | 0.811                                 | 0.557                                  | 0.700                                  | 0.447                                  | 0.796                 | 1.245                 | 0.829    | 1.526                 | 75.1      |
| 18   | 0.0478   | 3.2                    | 1.057                                 | 0.928                                 | 0.638                                  | 0.798                                  | 0.511                                  | 0.800                 | 1.248                 | 0.829    | 1.518                 | 74.8      |
| 17   | 0.0538   | 3.6                    | 1.191                                 | 1.046                                 | 0.719                                  | 0.895                                  | 0.575                                  | 0.804                 | 1.250                 | 0.829    | 1.510                 | 74.5      |
| 16   | 0.0598   | 4.0                    | 1.325                                 | 1.164                                 | 0.800                                  | 0.992                                  | 0.639                                  | 0.807                 | 1.253                 | 0.829    | 1.502                 | 74.2      |

| GRADE 50: F <sub>y</sub> = 50 ksi, F <sub>u</sub> = 65 ksi |  |  |  |  |  |  |                            |                            |                              |                              |                        |                        |
|--|--|--|--|--|--|--|----------------------------|----------------------------|------------------------------|------------------------------|------------------------|------------------------|
| Gage   | I <sub>e+</sub><br>in <sup>4</sup> /ft | I <sub>e-</sub><br>in <sup>4</sup> /ft | I <sub>d+</sub><br>in <sup>4</sup> /ft | I <sub>d-</sub><br>in <sup>4</sup> /ft | S <sub>e+</sub><br>in <sup>3</sup> /ft | S <sub>e-</sub><br>in <sup>3</sup> /ft | M <sub>n+</sub><br>k-ft/ft | M <sub>n-</sub><br>k-ft/ft | M <sub>nxt+</sub><br>k-ft/ft | M <sub>nxt-</sub><br>k-ft/ft | V <sub>n</sub><br>k/ft | T <sub>n</sub><br>k/ft |
| 22   | 0.332                                  | 0.296                                  | 0.354                                  | 0.330                                  | 0.269                                  | 0.211                                  | 1.121                      | 0.880                      | 2.098                        | 1.335                        | 3.508                  | 28.92                  |
| 21   | 0.366                                  | 0.336                                  | 0.390                                  | 0.370                                  | 0.302                                  | 0.245                                  | 1.258                      | 1.022                      | 2.305                        | 1.468                        | 3.848                  | 31.84                  |
| 20   | 0.400                                  | 0.376                                  | 0.426                                  | 0.410                                  | 0.333                                  | 0.281                                  | 1.386                      | 1.172                      | 2.511                        | 1.602                        | 4.185                  | 34.77                  |
| 19   | 0.466                                  | 0.457                                  | 0.497                                  | 0.490                                  | 0.393                                  | 0.358                                  | 1.638                      | 1.491                      | 2.915                        | 1.864                        | 4.842                  | 40.54                  |
| 18   | 0.534                                  | 0.540                                  | 0.569                                  | 0.573                                  | 0.454                                  | 0.443                                  | 1.894                      | 1.847                      | 3.323                        | 2.130                        | 5.501                  | 46.42                  |
| 17   | 0.602                                  | 0.625                                  | 0.641                                  | 0.657                                  | 0.513                                  | 0.514                                  | 2.139                      | 2.142                      | 3.729                        | 2.397                        | 6.151                  | 52.31                  |
| 16   | 0.670                                  | 0.709                                  | 0.713                                  | 0.739                                  | 0.571                                  | 0.586                                  | 2.380                      | 2.440                      | 4.133                        | 2.663                        | 6.791                  | 58.22                  |

| R     | w <sub>tf</sub> | w <sub>bf</sub> |
|-------|-----------------|-----------------|
| in.   | in.             | in.             |
| 0.188 | 1.275           | 4.704           |

| d <sub>p</sub> | c <sub>p</sub> |
|----------------|----------------|
| in.            | in.            |
| 0.156          | 0.375          |



Non-Composite Profiles

3.5DS-24

Composite Profiles

3.5DS-24 FL

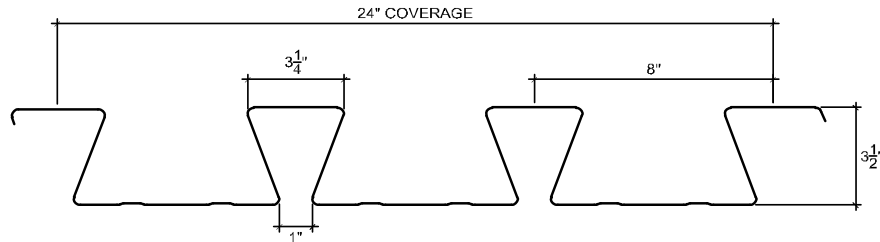

| Gage | t<br>in. | w <sub>dd</sub><br>psf | A <sub>g</sub><br>in <sup>2</sup> /ft | I <sub>xg</sub><br>in <sup>4</sup> /ft | S <sub>xb</sub><br>in <sup>3</sup> /ft | S <sub>xt</sub><br>in <sup>3</sup> /ft | y <sub>b</sub><br>in. | y <sub>t</sub><br>in. | r<br>in. | h <sub>w</sub><br>in. | θ<br>deg. | K <sub>min</sub><br>- |
|------|----------|------------------------|---------------------------------------|--|--|--|-----------------------|-----------------------|----------|-----------------------|-----------|-----------------------|
| 20   | 0.0359   | 3.4                    | 0.991                                 | 2.126                                  | 1.386                                  | 1.062                                  | 1.534                 | 2.002                 | 1.465    | 3.124                 | 71.1      | 0.00                  |
| 19   | 0.0418   | 3.9                    | 1.154                                 | 2.477                                  | 1.611                                  | 1.236                                  | 1.537                 | 2.004                 | 1.465    | 3.117                 | 70.9      | 0.00                  |
| 18   | 0.0478   | 4.5                    | 1.321                                 | 2.835                                  | 1.840                                  | 1.412                                  | 1.541                 | 2.007                 | 1.465    | 3.110                 | 70.8      | 0.00                  |
| 17   | 0.0538   | 5.1                    | 1.488                                 | 3.193                                  | 2.068                                  | 1.589                                  | 1.544                 | 2.010                 | 1.465    | 3.103                 | 70.6      | 0.00                  |
| 16   | 0.0598   | 5.6                    | 1.656                                 | 3.552                                  | 2.296                                  | 1.765                                  | 1.548                 | 2.012                 | 1.465    | 3.097                 | 70.5      | 0.00                  |

| GRADE 50: F <sub>y</sub> = 50 ksi, F <sub>u</sub> = 65 ksi |  |  |  |  |  |  |                            |                            |                              |                              |                        |                        |
|--|--|--|--|--|--|--|----------------------------|----------------------------|------------------------------|------------------------------|------------------------|------------------------|
| Gage   | I <sub>e+</sub><br>in <sup>4</sup> /ft | I <sub>e-</sub><br>in <sup>4</sup> /ft | I <sub>d+</sub><br>in <sup>4</sup> /ft | I <sub>d-</sub><br>in <sup>4</sup> /ft | S <sub>e+</sub><br>in <sup>3</sup> /ft | S <sub>e-</sub><br>in <sup>3</sup> /ft | M <sub>n+</sub><br>k-ft/ft | M <sub>n-</sub><br>k-ft/ft | M <sub>nxt+</sub><br>k-ft/ft | M <sub>nxt-</sub><br>k-ft/ft | V <sub>n</sub><br>k/ft | T <sub>n</sub><br>k/ft |
| 20   | 1.863                                  | 1.644                                  | 1.951                                  | 1.805                                  | 0.714                                  | 0.757                                  | 2.975                      | 3.155                      | 5.774                        | 4.424                        | 6.006                  | 49.54                  |
| 19   | 2.227                                  | 1.982                                  | 2.310                                  | 2.147                                  | 0.883                                  | 0.926                                  | 3.680                      | 3.857                      | 6.713                        | 5.149                        | 8.344                  | 57.72                  |
| 18   | 2.605                                  | 2.339                                  | 2.681                                  | 2.505                                  | 1.052                                  | 1.108                                  | 4.385                      | 4.618                      | 7.666                        | 5.885                        | 10.901                 | 66.06                  |
| 17   | 2.982                                  | 2.708                                  | 3.053                                  | 2.870                                  | 1.230                                  | 1.302                                  | 5.123                      | 5.424                      | 8.617                        | 6.621                        | 13.797                 | 74.42                  |
| 16   | 3.356                                  | 3.088                                  | 3.421                                  | 3.243                                  | 1.414                                  | 1.505                                  | 5.890                      | 6.273                      | 9.565                        | 7.356                        | 15.650                 | 82.78                  |

| Gage | A <sub>gbf</sub><br>in <sup>2</sup> | A <sub>sbf</sub><br>in <sup>2</sup> | I <sub>spbf</sub><br>in <sup>4</sup> |
|------|-------------------------------------|-------------------------------------|--------------------------------------|
| 20   | 0.233                               | 0.028                               | 6.54E-05                             |
| 19   | 0.272                               | 0.032                               | 7.75E-05                             |
| 18   | 0.311                               | 0.037                               | 9.05E-05                             |
| 17   | 0.350                               | 0.042                               | 1.04E-04                             |
| 16   | 0.389                               | 0.046                               | 1.19E-04                             |

| R     | w <sub>tf</sub> | w <sub>bf</sub> |
|-------|-----------------|-----------------|
| in.   | in.             | in.             |
| 0.188 | 2.795           | 6.454           |

| b <sub>obf</sub> | b <sub>pbf</sub> | c <sub>sbf</sub> |
|------------------|------------------|------------------|
| in.              | in.              | in.              |
| 6.454            | 1.750            | 1.977            |



Acoustic Profiles

3.5DS-24 AC

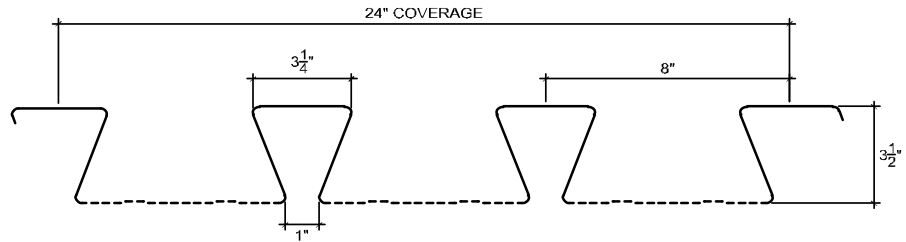

| Gage | t<br>in. | w <sub>dd</sub><br>psf | A <sub>g</sub><br>in <sup>2</sup> /ft | A <sub>n</sub><br>in <sup>2</sup> /ft | I <sub>xg</sub><br>in <sup>4</sup> /ft | S <sub>xb</sub><br>in <sup>3</sup> /ft | S <sub>xt</sub><br>in <sup>3</sup> /ft | y <sub>b</sub><br>in. | y <sub>t</sub><br>in. | r<br>in. | h <sub>w</sub><br>in. | θ<br>deg. |
|------|----------|------------------------|---------------------------------------|---------------------------------------|--|--|--|-----------------------|-----------------------|----------|-----------------------|-----------|
| 20   | 0.0359   | 3.2                    | 0.991                                 | 0.936                                 | 1.978                                  | 1.219                                  | 1.034                                  | 1.623                 | 1.913                 | 1.454    | 3.124                 | 71.1      |
| 19   | 0.0418   | 3.7                    | 1.154                                 | 1.090                                 | 2.305                                  | 1.417                                  | 1.203                                  | 1.626                 | 1.916                 | 1.454    | 3.117                 | 70.9      |
| 18   | 0.0478   | 4.2                    | 1.321                                 | 1.248                                 | 2.638                                  | 1.619                                  | 1.375                                  | 1.629                 | 1.918                 | 1.454    | 3.110                 | 70.8      |
| 17   | 0.0538   | 4.8                    | 1.488                                 | 1.406                                 | 2.971                                  | 1.820                                  | 1.547                                  | 1.633                 | 1.921                 | 1.454    | 3.103                 | 70.6      |
| 16   | 0.0598   | 5.3                    | 1.656                                 | 1.564                                 | 3.306                                  | 2.021                                  | 1.718                                  | 1.636                 | 1.924                 | 1.454    | 3.097                 | 70.5      |

| GRADE 50: F <sub>y</sub> = 50 ksi, F <sub>u</sub> = 65 ksi |  |  |  |  |  |  |                            |                            |                              |                              |                        |                        |
|--|--|--|--|--|--|--|----------------------------|----------------------------|------------------------------|------------------------------|------------------------|------------------------|
| Gage   | I <sub>e+</sub><br>in <sup>4</sup> /ft | I <sub>e-</sub><br>in <sup>4</sup> /ft | I <sub>d+</sub><br>in <sup>4</sup> /ft | I <sub>d-</sub><br>in <sup>4</sup> /ft | S <sub>e+</sub><br>in <sup>3</sup> /ft | S <sub>e-</sub><br>in <sup>3</sup> /ft | M <sub>n+</sub><br>k-ft/ft | M <sub>n-</sub><br>k-ft/ft | M <sub>nxt+</sub><br>k-ft/ft | M <sub>nxt-</sub><br>k-ft/ft | V <sub>n</sub><br>k/ft | T <sub>n</sub><br>k/ft |
| 20   | 1.541                                  | 1.480                                  | 1.687                                  | 1.646                                  | 0.674                                  | 0.665                                  | 2.809                      | 2.771                      | 5.078                        | 4.307                        | 6.006                  | 46.78                  |
| 19   | 1.842                                  | 1.811                                  | 1.996                                  | 1.975                                  | 0.823                                  | 0.825                                  | 3.427                      | 3.437                      | 5.906                        | 5.013                        | 8.344                  | 54.52                  |
| 18   | 2.150                                  | 2.163                                  | 2.313                                  | 2.321                                  | 0.982                                  | 0.999                                  | 4.091                      | 4.162                      | 6.746                        | 5.729                        | 10.901                 | 62.40                  |
| 17   | 2.457                                  | 2.530                                  | 2.628                                  | 2.677                                  | 1.149                                  | 1.184                                  | 4.787                      | 4.934                      | 7.583                        | 6.445                        | 13.797                 | 70.29                  |
| 16   | 2.760                                  | 2.907                                  | 2.942                                  | 3.040                                  | 1.322                                  | 1.380                                  | 5.510                      | 5.750                      | 8.419                        | 7.160                        | 15.650                 | 78.19                  |

| Gage | A <sub>gbf</sub><br>in <sup>2</sup> | A <sub>sbf</sub><br>in <sup>2</sup> | I <sub>spbf</sub><br>in <sup>4</sup> |
|------|-------------------------------------|-------------------------------------|--------------------------------------|
| 20   | 0.233                               | 0.028                               | 6.54E-05                             |
| 19   | 0.272                               | 0.032                               | 7.75E-05                             |
| 18   | 0.311                               | 0.037                               | 9.05E-05                             |
| 17   | 0.350                               | 0.042                               | 1.04E-04                             |
| 16   | 0.389                               | 0.046                               | 1.19E-04                             |

| R     | w <sub>tf</sub> | w <sub>bf</sub> |
|-------|-----------------|-----------------|
| in.   | in.             | in.             |
| 0.188 | 2.795           | 6.454           |

| b <sub>obf</sub> | b <sub>pbf</sub> | c <sub>sbf</sub> |
|------------------|------------------|------------------|
| in.              | in.              | in.              |
| 6.454            | 1.750            | 1.977            |

| d <sub>p</sub> | c <sub>p</sub> |
|----------------|----------------|
| in.            | in.            |
| 0.156          | 0.375          |



Acoustic Profiles

3.5DS-24 ACW

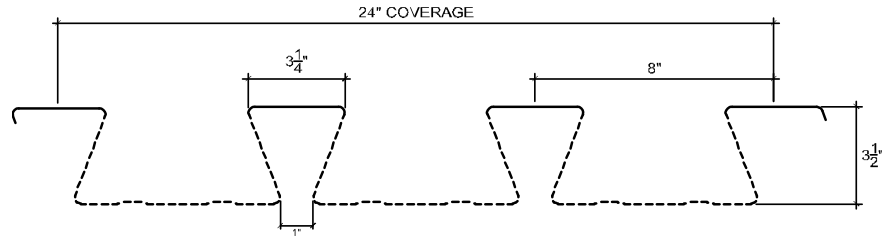

| Gage | t<br>in. | w <sub>dd</sub><br>psf | A <sub>g</sub><br>in <sup>2</sup> /ft | A <sub>n</sub><br>in <sup>2</sup> /ft | I <sub>xg</sub><br>in <sup>4</sup> /ft | S <sub>xb</sub><br>in <sup>3</sup> /ft | S <sub>xt</sub><br>in <sup>3</sup> /ft | y <sub>b</sub><br>in. | y <sub>t</sub><br>in. | r<br>in. | h <sub>w</sub><br>in. | θ<br>deg. |
|------|----------|------------------------|---------------------------------------|---------------------------------------|--|--|--|-----------------------|-----------------------|----------|-----------------------|-----------|
| 20   | 0.0359   | 3.0                    | 0.991                                 | 0.876                                 | 1.922                                  | 1.183                                  | 1.006                                  | 1.625                 | 1.911                 | 1.481    | 3.124                 | 71.1      |
| 19   | 0.0418   | 3.5                    | 1.154                                 | 1.021                                 | 2.240                                  | 1.375                                  | 1.171                                  | 1.629                 | 1.913                 | 1.481    | 3.117                 | 70.9      |
| 18   | 0.0478   | 4.0                    | 1.321                                 | 1.169                                 | 2.564                                  | 1.571                                  | 1.338                                  | 1.632                 | 1.915                 | 1.481    | 3.110                 | 70.8      |
| 17   | 0.0538   | 4.5                    | 1.488                                 | 1.316                                 | 2.888                                  | 1.766                                  | 1.506                                  | 1.636                 | 1.918                 | 1.481    | 3.103                 | 70.6      |
| 16   | 0.0598   | 5.0                    | 1.656                                 | 1.465                                 | 3.213                                  | 1.960                                  | 1.673                                  | 1.639                 | 1.920                 | 1.481    | 3.097                 | 70.5      |

| GRADE 50: F <sub>y</sub> = 50 ksi, F <sub>u</sub> = 65 ksi |  |  |  |  |  |  |                            |                            |                              |                              |                        |                        |
|--|--|--|--|--|--|--|----------------------------|----------------------------|------------------------------|------------------------------|------------------------|------------------------|
| Gage   | I <sub>e+</sub><br>in <sup>4</sup> /ft | I <sub>e-</sub><br>in <sup>4</sup> /ft | I <sub>d+</sub><br>in <sup>4</sup> /ft | I <sub>d-</sub><br>in <sup>4</sup> /ft | S <sub>e+</sub><br>in <sup>3</sup> /ft | S <sub>e-</sub><br>in <sup>3</sup> /ft | M <sub>n+</sub><br>k-ft/ft | M <sub>n-</sub><br>k-ft/ft | M <sub>nxt+</sub><br>k-ft/ft | M <sub>nxt-</sub><br>k-ft/ft | V <sub>n</sub><br>k/ft | T <sub>n</sub><br>k/ft |
| 20   | 1.431                                  | 1.347                                  | 1.595                                  | 1.539                                  | 0.632                                  | 0.570                                  | 2.634                      | 2.376                      | 4.927                        | 4.192                        | 3.950                  | 43.80                  |
| 19   | 1.707                                  | 1.680                                  | 1.885                                  | 1.867                                  | 0.774                                  | 0.727                                  | 3.225                      | 3.027                      | 5.730                        | 4.879                        | 5.486                  | 51.05                  |
| 18   | 1.988                                  | 2.015                                  | 2.180                                  | 2.198                                  | 0.927                                  | 0.885                                  | 3.861                      | 3.689                      | 6.544                        | 5.577                        | 7.168                  | 58.43                  |
| 17   | 2.267                                  | 2.371                                  | 2.474                                  | 2.543                                  | 1.087                                  | 1.062                                  | 4.528                      | 4.424                      | 7.356                        | 6.275                        | 9.072                  | 65.82                  |
| 16   | 2.542                                  | 2.736                                  | 2.766                                  | 2.895                                  | 1.253                                  | 1.249                                  | 5.222                      | 5.204                      | 8.166                        | 6.972                        | 10.291                 | 73.23                  |

| Gage | A <sub>gbf</sub><br>in <sup>2</sup> | A <sub>sbf</sub><br>in <sup>2</sup> | I <sub>spbf</sub><br>in <sup>4</sup> |
|------|-------------------------------------|-------------------------------------|--------------------------------------|
| 20   | 0.233                               | 0.028                               | 6.54E-05                             |
| 19   | 0.272                               | 0.032                               | 7.75E-05                             |
| 18   | 0.311                               | 0.037                               | 9.05E-05                             |
| 17   | 0.350                               | 0.042                               | 1.04E-04                             |
| 16   | 0.389                               | 0.046                               | 1.19E-04                             |

| R     | w <sub>tr</sub> | w <sub>br</sub> |
|-------|-----------------|-----------------|
| in.   | in.             | in.             |
| 0.188 | 2.795           | 6.454           |

| b <sub>obf</sub> | b <sub>pbf</sub> | c <sub>sbf</sub> |
|------------------|------------------|------------------|
| in.              | in.              | in.              |
| 6.454            | 1.750            | 1.977            |

| d <sub>p</sub> | c <sub>p</sub> |
|----------------|----------------|
| in.            | in.            |
| 0.156          | 0.375          |



Non-Composite Profiles

3.5DF-24

Composite Profiles

3.5DF-24 FL

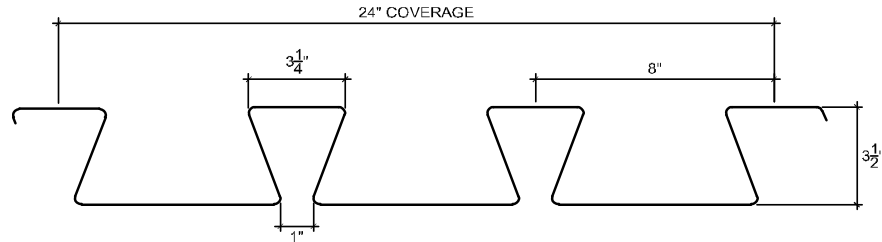

| Gage | t<br>in. | w <sub>dd</sub><br>psf | A <sub>g</sub><br>in <sup>2</sup> /ft | I <sub>xg</sub><br>in <sup>4</sup> /ft | S <sub>xb</sub><br>in <sup>3</sup> /ft | S <sub>xt</sub><br>in <sup>3</sup> /ft | y <sub>b</sub><br>in. | y <sub>t</sub><br>in. | r<br>in. | h <sub>w</sub><br>in. | θ<br>deg. | K <sub>min</sub><br>- |
|------|----------|------------------------|---------------------------------------|--|--|--|-----------------------|-----------------------|----------|-----------------------|-----------|-----------------------|
| 20   | 0.0359   | 3.4                    | 0.989                                 | 2.131                                  | 1.389                                  | 1.064                                  | 1.534                 | 2.002                 | 1.468    | 3.124                 | 71.1      | 0.00                  |
| 19   | 0.0418   | 3.9                    | 1.152                                 | 2.483                                  | 1.615                                  | 1.239                                  | 1.537                 | 2.005                 | 1.468    | 3.117                 | 70.9      | 0.00                  |
| 18   | 0.0478   | 4.5                    | 1.318                                 | 2.842                                  | 1.845                                  | 1.416                                  | 1.541                 | 2.007                 | 1.468    | 3.110                 | 70.8      | 0.00                  |
| 17   | 0.0538   | 5.1                    | 1.485                                 | 3.201                                  | 2.073                                  | 1.593                                  | 1.544                 | 2.010                 | 1.468    | 3.103                 | 70.6      | 0.00                  |
| 16   | 0.0598   | 5.6                    | 1.652                                 | 3.561                                  | 2.301                                  | 1.770                                  | 1.548                 | 2.012                 | 1.468    | 3.097                 | 70.5      | 0.00                  |

| GRADE 50: F <sub>y</sub> = 50 ksi, F <sub>u</sub> = 65 ksi |  |  |  |  |  |  |                            |                            |                              |                              |                        |                        |
|--|--|--|--|--|--|--|----------------------------|----------------------------|------------------------------|------------------------------|------------------------|------------------------|
| Gage   | I <sub>e+</sub><br>in <sup>4</sup> /ft | I <sub>e-</sub><br>in <sup>4</sup> /ft | I <sub>d+</sub><br>in <sup>4</sup> /ft | I <sub>d-</sub><br>in <sup>4</sup> /ft | S <sub>e+</sub><br>in <sup>3</sup> /ft | S <sub>e-</sub><br>in <sup>3</sup> /ft | M <sub>n+</sub><br>k-ft/ft | M <sub>n-</sub><br>k-ft/ft | M <sub>nxt+</sub><br>k-ft/ft | M <sub>nxt-</sub><br>k-ft/ft | V <sub>n</sub><br>k/ft | T <sub>n</sub><br>k/ft |
| 20   | 1.868                                  | 1.594                                  | 1.956                                  | 1.773                                  | 0.716                                  | 0.628                                  | 2.982                      | 2.615                      | 5.789                        | 4.435                        | 6.006                  | 49.43                  |
| 19   | 2.233                                  | 1.948                                  | 2.316                                  | 2.126                                  | 0.886                                  | 0.774                                  | 3.690                      | 3.227                      | 6.730                        | 5.162                        | 8.344                  | 57.59                  |
| 18   | 2.612                                  | 2.323                                  | 2.688                                  | 2.496                                  | 1.055                                  | 0.935                                  | 4.397                      | 3.897                      | 7.686                        | 5.900                        | 10.901                 | 65.91                  |
| 17   | 2.990                                  | 2.709                                  | 3.060                                  | 2.873                                  | 1.233                                  | 1.107                                  | 5.136                      | 4.612                      | 8.638                        | 6.637                        | 13.797                 | 74.25                  |
| 16   | 3.364                                  | 3.104                                  | 3.430                                  | 3.256                                  | 1.417                                  | 1.289                                  | 5.905                      | 5.372                      | 9.588                        | 7.374                        | 15.650                 | 82.59                  |

| R     | w <sub>tf</sub> | w <sub>bf</sub> |
|-------|-----------------|-----------------|
| in.   | in.             | in.             |
| 0.188 | 2.795           | 6.454           |



# EVALUATION REPORT

Number:

0423

Originally Issued: 03/10/2017

Revised: 04/02/2024

Valid Through: 03/31/2025

Page 33 of 34

Acoustic Profiles

3.5DF-24 AC

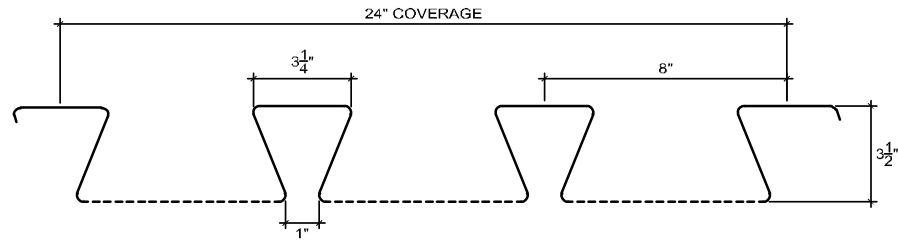

| Gage | t<br>in. | w <sub>dd</sub><br>psf | A <sub>g</sub><br>in <sup>2</sup> /ft | A <sub>n</sub><br>in <sup>2</sup> /ft | I <sub>xg</sub><br>in <sup>4</sup> /ft | S <sub>xb</sub><br>in <sup>3</sup> /ft | S <sub>xt</sub><br>in <sup>3</sup> /ft | y <sub>b</sub><br>in. | y <sub>t</sub><br>in. | r<br>in. | h <sub>w</sub><br>in. | θ<br>deg. |
|------|----------|------------------------|---------------------------------------|---------------------------------------|--|--|--|-----------------------|-----------------------|----------|-----------------------|-----------|
| 20   | 0.0359   | 3.2                    | 0.989                                 | 0.934                                 | 1.982                                  | 1.222                                  | 1.036                                  | 1.623                 | 1.913                 | 1.457    | 3.124                 | 71.1      |
| 19   | 0.0418   | 3.7                    | 1.152                                 | 1.088                                 | 2.310                                  | 1.421                                  | 1.206                                  | 1.626                 | 1.916                 | 1.457    | 3.117                 | 70.9      |
| 18   | 0.0478   | 4.2                    | 1.318                                 | 1.245                                 | 2.644                                  | 1.622                                  | 1.378                                  | 1.629                 | 1.918                 | 1.457    | 3.110                 | 70.8      |
| 17   | 0.0538   | 4.8                    | 1.485                                 | 1.403                                 | 2.978                                  | 1.824                                  | 1.550                                  | 1.633                 | 1.921                 | 1.457    | 3.103                 | 70.6      |
| 16   | 0.0598   | 5.3                    | 1.652                                 | 1.561                                 | 3.313                                  | 2.025                                  | 1.722                                  | 1.636                 | 1.924                 | 1.457    | 3.097                 | 70.5      |

| GRADE 50: F <sub>y</sub> = 50 ksi, F <sub>u</sub> = 65 ksi |  |  |  |  |  |  |                            |                            |                              |                              |                        |                        |
|--|--|--|--|--|--|--|----------------------------|----------------------------|------------------------------|------------------------------|------------------------|------------------------|
| Gage   | I <sub>e+</sub><br>in <sup>4</sup> /ft | I <sub>e-</sub><br>in <sup>4</sup> /ft | I <sub>d+</sub><br>in <sup>4</sup> /ft | I <sub>d-</sub><br>in <sup>4</sup> /ft | S <sub>e+</sub><br>in <sup>3</sup> /ft | S <sub>e-</sub><br>in <sup>3</sup> /ft | M <sub>n+</sub><br>k-ft/ft | M <sub>n-</sub><br>k-ft/ft | M <sub>nxt+</sub><br>k-ft/ft | M <sub>nxt-</sub><br>k-ft/ft | V <sub>n</sub><br>k/ft | T <sub>n</sub><br>k/ft |
| 20   | 1.545                                  | 1.446                                  | 1.690                                  | 1.624                                  | 0.676                                  | 0.565                                  | 2.816                      | 2.354                      | 5.090                        | 4.317                        | 6.006                  | 46.69                  |
| 19   | 1.846                                  | 1.755                                  | 2.001                                  | 1.940                                  | 0.825                                  | 0.694                                  | 3.436                      | 2.890                      | 5.919                        | 5.024                        | 8.344                  | 54.41                  |
| 18   | 2.155                                  | 2.080                                  | 2.318                                  | 2.268                                  | 0.984                                  | 0.834                                  | 4.101                      | 3.476                      | 6.760                        | 5.742                        | 10.901                 | 62.27                  |
| 17   | 2.461                                  | 2.420                                  | 2.634                                  | 2.606                                  | 1.151                                  | 0.985                                  | 4.798                      | 4.102                      | 7.599                        | 6.459                        | 13.797                 | 70.15                  |
| 16   | 2.765                                  | 2.764                                  | 2.948                                  | 2.947                                  | 1.325                                  | 1.144                                  | 5.523                      | 4.768                      | 8.437                        | 7.176                        | 15.650                 | 78.04                  |

| R     | w <sub>tr</sub> | w <sub>br</sub> |
|-------|-----------------|-----------------|
| in.   | in.             | in.             |
| 0.188 | 2.795           | 6.454           |

| d <sub>p</sub> | c <sub>p</sub> |
|----------------|----------------|
| in.            | in.            |
| 0.156          | 0.375          |



Acoustic Profiles

3.5DF-24 ACW

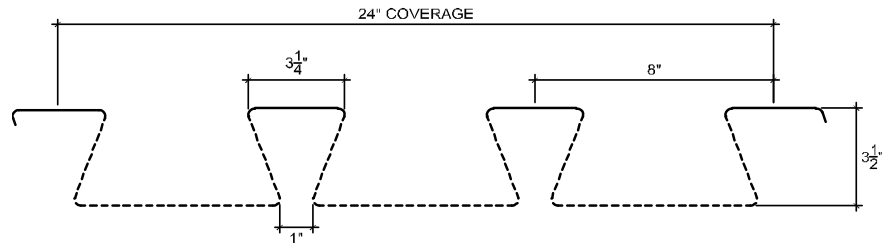

| Gage | t<br>in. | w <sub>dd</sub><br>psf | A <sub>g</sub><br>in <sup>2</sup> /ft | A <sub>n</sub><br>in <sup>2</sup> /ft | I <sub>xg</sub><br>in <sup>4</sup> /ft | S <sub>xb</sub><br>in <sup>3</sup> /ft | S <sub>xt</sub><br>in <sup>3</sup> /ft | y <sub>b</sub><br>in. | y <sub>t</sub><br>in. | r<br>in. | h <sub>w</sub><br>in. | θ<br>deg. |
|------|----------|------------------------|---------------------------------------|---------------------------------------|--|--|--|-----------------------|-----------------------|----------|-----------------------|-----------|
| 20   | 0.0359   | 3.0                    | 0.989                                 | 0.874                                 | 1.927                                  | 1.185                                  | 1.008                                  | 1.625                 | 1.911                 | 1.485    | 3.124                 | 71.1      |
| 19   | 0.0418   | 3.5                    | 1.152                                 | 1.019                                 | 2.245                                  | 1.378                                  | 1.174                                  | 1.629                 | 1.913                 | 1.485    | 3.117                 | 70.9      |
| 18   | 0.0478   | 4.0                    | 1.318                                 | 1.166                                 | 2.570                                  | 1.574                                  | 1.342                                  | 1.632                 | 1.915                 | 1.484    | 3.110                 | 70.8      |
| 17   | 0.0538   | 4.4                    | 1.485                                 | 1.303                                 | 2.864                                  | 1.738                                  | 1.503                                  | 1.648                 | 1.906                 | 1.482    | 3.103                 | 70.6      |
| 16   | 0.0598   | 5.0                    | 1.652                                 | 1.461                                 | 3.220                                  | 1.964                                  | 1.677                                  | 1.640                 | 1.920                 | 1.484    | 3.097                 | 70.5      |

| GRADE 50: F <sub>y</sub> = 50 ksi, F <sub>u</sub> = 65 ksi |  |  |  |  |  |  |                            |                            |                              |                              |                        |                        |
|--|--|--|--|--|--|--|----------------------------|----------------------------|------------------------------|------------------------------|------------------------|------------------------|
| Gage   | I <sub>e+</sub><br>in <sup>4</sup> /ft | I <sub>e-</sub><br>in <sup>4</sup> /ft | I <sub>d+</sub><br>in <sup>4</sup> /ft | I <sub>d-</sub><br>in <sup>4</sup> /ft | S <sub>e+</sub><br>in <sup>3</sup> /ft | S <sub>e-</sub><br>in <sup>3</sup> /ft | M <sub>n+</sub><br>k-ft/ft | M <sub>n-</sub><br>k-ft/ft | M <sub>nxt+</sub><br>k-ft/ft | M <sub>nxt-</sub><br>k-ft/ft | V <sub>n</sub><br>k/ft | T <sub>n</sub><br>k/ft |
| 20   | 1.435                                  | 1.305                                  | 1.599                                  | 1.512                                  | 0.634                                  | 0.485                                  | 2.641                      | 2.022                      | 4.939                        | 4.202                        | 3.950                  | 43.71                  |
| 19   | 1.711                                  | 1.596                                  | 1.889                                  | 1.812                                  | 0.776                                  | 0.607                                  | 3.233                      | 2.527                      | 5.743                        | 4.890                        | 5.486                  | 50.94                  |
| 18   | 1.992                                  | 1.905                                  | 2.185                                  | 2.127                                  | 0.929                                  | 0.741                                  | 3.871                      | 3.086                      | 6.559                        | 5.590                        | 7.168                  | 58.30                  |
| 17   | 2.171                                  | 2.132                                  | 2.402                                  | 2.376                                  | 1.070                                  | 0.845                                  | 4.457                      | 3.523                      | 7.242                        | 6.262                        | 9.072                  | 65.17                  |
| 16   | 2.548                                  | 2.549                                  | 2.772                                  | 2.773                                  | 1.256                                  | 1.040                                  | 5.234                      | 4.332                      | 8.184                        | 6.988                        | 10.291                 | 73.07                  |

| R     | w <sub>tr</sub> | w <sub>br</sub> |
|-------|-----------------|-----------------|
| in.   | in.             | in.             |
| 0.188 | 2.795           | 6.454           |

| d <sub>p</sub> | c <sub>p</sub> |
|----------------|----------------|
| in.            | in.            |
| 0.156          | 0.375          |